



2/01/2021



Amateur Radio

Foundation Licence Training

Conducted by the Eastern and
Mountain District Radio Club (EMDRC)



Introductions

- ▶ Round table (brief)
 - ▶ What is your name?
 - ▶ What you do for a job?
 - ▶ Why are you interested in amateur radio?
 - ▶ What is your favorite holiday destination?

Acknowledgement of Traditional Owners

- ▶ We acknowledge the Traditional Owners of the land on which we are meeting today. We pay our respects to their Elders, past, present and emerging, and the Aboriginal Elders of other communities who may be here today.





COVID-19 Safety Requirements

- ▶ Now that restrictions have eased
 - ▶ Please obey signs placed about the building
 - ▶ Adhere to social distancing rules
 - ▶ Keep your belongings on or under your allocated table
 - ▶ Use the hand sanitiser provided
 - ▶ Do not share food or drinks



Syllabus

- ▶ 1. Nature of Amateur Radio
- ▶ 2. Licence Conditions
- ▶ 3. Technical Basics
- ▶ 4. Transmitters and Receivers
- ▶ 5. Transmission Lines and Antennas
- ▶ 6. Propagation
- ▶ 7. Interference
- ▶ 8. Operating Practices and Procedures
- ▶ 9. Safety



Study Documents

- ▶ To study for the Foundation Licence you should have a copy of the following documents:
 - ▶ Foundation Licence Syllabus
https://www.amc.edu.au/__data/assets/pdf_file/0013/1221610/Foundation-Syllabus-update-12-Oct-2020-FINAL.pdf
 - ▶ Foundation Licence Conditions Determination (LCD)
<https://www.legislation.gov.au/Details/F2020C00376>
 - ▶ The Foundation Licence Manual (Third Edition)
http://www.wia.org.au/members/bookshop/page_data.php?id=113
- ▶ Assessments are conducted by independent assessors that have been approved by the Australian Maritime College (AMC)
<http://www.amc.edu.au/industry/amateur-radio/assessors>



Examination

- ▶ Contains 25 multiple choice questions consisting of both theory and regulations
- ▶ Allows up to 30 minutes for completion
- ▶ You must correctly answer at least 18 out of 25 questions to pass (70%)
- ▶ Followed by a practical session of about 30 to 40 minutes
- ▶ All sections of the practical must be completed (i.e. 100% to pass)
- ▶ Practical requires hands-on activities interacting with the assessor



2/01/2021



Section 1

The Nature of Amateur Radio

Author: Peter Hartfield VK3PH - Version: 3-2021



1. The Nature of Amateur Radio

▶ The Nature of Amateur Radio

- ▶ Amateur radio is intended to facilitate hobby radiocommunications.

▶ Types of licences

- ▶ Amateur radio activities are authorised under an amateur licence. Other forms of licences authorise types of radiocommunications such as Citizens Band (CB), Land mobile, Point to Point Links and Broadcasting.
- ▶ The Amateur Service operates on frequency bands allocated for Amateur use. The Amateur Service shares some frequency bands with other services.



1. The Nature of Amateur Radio

- ▶ Allocation of frequency bands
 - ▶ Services such as the broadcasting, aeronautical and maritime services are allocated frequency bands appropriate to their purpose
- ▶ Amateur Radio Band Plans
 - ▶ <http://www.wia.org.au/members/bandplans/data/>

40 metre band – All licence classes

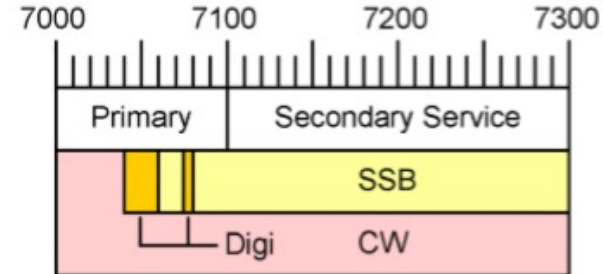

7.000 - 7.300
7.040 - 7.060
7.060 - 7.074
7.074
7.074 - 7.080
7.080 - 7.300
7.110

CW
Digital data modes
SSB (shared with international digimode activity)
WICEN frequency (interim)
Digital data modes
SSB
IARU Region III emergency centre frequency

(Note 1)
(Note 2)

(Note 1)
(Note 2)



1. The Nature of Amateur Radio

- ▶ The following is a typical question you may be asked in the foundation licence theory exam:
 - ▶ A Radio Amateur's Licence allows the amateur to operate on the:
 - ▶ A). Marine Band
 - ▶ B). Broadcast Band
 - ▶ C). Amateur Band
 - ▶ D). Aeronautical Band

2/01/2021



DANGER

**CONSTRUCTION
SITE**

NO UNAUTHORISED ENTR

Section 2

Licence Conditions



2. Licence Conditions

- ▶ Operation under a Foundation Amateur Licence is subject to conditions in the:
 - ▶ *Radiocommunications Act 1992*,
<https://www.legislation.gov.au/Details/C2019C00262>
 - ▶ *Radiocommunications Regulations 1993*,
<https://www.legislation.gov.au/Details/F2019C00711>
 - ▶ *Radiocommunications Licence Conditions (Amateur Licence) Determination 2015 (as amended from time to time)* and
<https://www.legislation.gov.au/Details/F2020C00376>
 - ▶ Part 6 - Conditions for amateur licence (amateur foundation station)
 - ▶ *Radiocommunications Licence Conditions (Apparatus Licence) Determination 2015*
<https://www.legislation.gov.au/Details/F2019C00870>



2. Licence Conditions

- ▶ An Amateur Licence primarily authorises the operation of an Amateur station
 - ▶ for self-training in radiocommunications,
 - ▶ intercommunications between Amateurs and
 - ▶ technical investigations into radiocommunications.
- ▶ An Amateur Licence only authorises Amateur-to-Amateur communications
 - ▶ except in relation to a distress or emergency situation,
 - ▶ or where authorised by an Inspector



2. Licence Conditions

- ▶ Messages may be passed on behalf of third parties as long as they do not relate to the business or financial affairs of any person.
 - ▶ This also applies to sending of third party messages via amateurs in other countries unless the foreign government has given notice of its objection to such messages.
- ▶ Radio Amateurs are permitted to send “third party” messages to other amateurs in Australia on behalf of a third person provided it is not for gain, commercial purpose an advertisement or entertainment or relate to the business or financial affairs of any person.
- ▶ Australian amateurs are permitted to send third party messages via amateurs in other countries unless the foreign government has given notice of its objection to such messages.



2. Licence Conditions

▶ Distress and Urgency Signals

- ▶ Distress communications are signalled by the use of “Mayday” and these communications have priority over all other communications
- ▶ Persons hearing a “Mayday” communication are responsible for passing the information on to an appropriate authority
- ▶ Some urgent situations not warranting the use of “Mayday” are signalled by the use of “Pan Pan”
- ▶ These communications should receive priority and should be reported to an appropriate authority



2. Licence Conditions

▶ Station identification

- ▶ Correct station identification is required at the beginning of a transmission, or series of transmissions, and
- ▶ At least every 10 minutes during a series of transmissions
- ▶ Any transmission, even a test transmission, must contain station identification



2. Licence Conditions

- ▶ Amateur callsigns
 - ▶ Commence with the prefix VK in Australia
 - ▶ Followed by a state identifier (0-9)
 - ▶ Followed by 2, 3 letters depending on the licence grade:

Licence class	Callsign Format (Note 1)
Advanced	VK\$aa, VJ\$a, VK\$a, VL\$a (Note 2) VK\$GGA-GGZ (Guides Aust), VK\$SAA-SDZ (Scouts Assoc.)
Advanced Standard Foundation	VK\$aaa-VK\$zzz (Note 3)
Repeater Beacon	VK\$Raa-VK\$Rzz (no change)



2. Licence Conditions

- ▶ Encoded messages
 - ▶ Transmission of messages that are encoded for the purpose of obscuring their meaning is not permitted except for the purposes specified in the Amateur LCD
- ▶ Entertainment and financial gain
 - ▶ The transmission of any form of entertainment is not permitted
 - ▶ An amateur station cannot be used for financial gain
- ▶ Authorised frequency bands and emissions
 - ▶ The Foundation Amateur Licence authorises operation on certain frequency bands and the use of certain emission modes
 - ▶ Recall what document the bands and modes are specified

2. Licence Conditions

- ▶ Permitted power output
 - ▶ The Foundation Amateur Licence restricts the transmitter output power to a maximum of 10 watts





2. Licence Conditions

- ▶ Notification of change of address
 - ▶ It is a requirement of the licence to notify the Australian Communications and Media Authority (ACMA) of any change of address
- ▶ Harmful interference
 - ▶ A licensee must not operate an Amateur station if operation causes harmful interference to radiocommunications
- ▶ Inspection of Amateur licences
 - ▶ Inspectors have the right to require an Amateur to produce his/her licence
- ▶ Restriction of operation to avoid interference
 - ▶ In order to avoid interference the ACMA has the right to restrict the operation of an Amateur Station



2. Licence Conditions

- ▶ The bands that radio amateurs are allocated are:
 - ▶ A). To make use of manufactured radio equipment
 - ▶ B). To allow use of the bands independent of the sun spot cycle
 - ▶ C). To minimize the likelihood of interference to other services
 - ▶ D). Totally eliminate interference



2. Licence Conditions

- ▶ A Foundation Licence holder may allow other persons operate their station if the person:
 - ▶ A). Is another licenced amateur
 - ▶ B). Is an Australian citizen
 - ▶ C). Has a Commonwealth passport
 - ▶ D). Is a member of the same family



2. Licence Conditions

- ▶ An amateur with a call sign VK4NSW would indicate:
 - ▶ A). A Queensland amateur
 - ▶ B). A Victorian amateur with a full call licence
 - ▶ C). A Queensland amateur with a standard licence
 - ▶ D). A Queensland amateur with a foundation licence



2. Licence Conditions

- ▶ What authorises amateur radio activities in Australia:
 - ▶ A). The LCD
 - ▶ B). The WIA
 - ▶ C). Certificate 3 in Electrotechnology
 - ▶ D). An amateur licence



2. Licence Conditions

- ▶ While listening to a frequency not in the amateur band you hear a mayday call. You must:
 - ▶ A). Tune to another frequency
 - ▶ B). Contact an advanced amateur
 - ▶ C). Report and provide assistance
 - ▶ D). Advise the person to change to an amateur frequency



2. Licence Conditions

- ▶ Who can require you to produce your amateur licence:
 - ▶ A). State police
 - ▶ B). WIA
 - ▶ C). ACMA Radio Inspectors
 - ▶ D). A person receiving interference

2/01/2021

Section 3

Technical Basics

Author: Peter Hartfield VK3PH - Version: 3-2021

28

3. Technical Basics

- ▶ The universe is made up of matter.
- ▶ All matter is made of atoms.
- ▶ Atoms are made up of electrically charged particles called protons and electrons.
 - ▶ These charged particles give rise to electricity as we understand it, and apply in today's electronic applications including Amateur Radio.
 - ▶ Atoms are always seeking to become discharged.
 - ▶ Electrons move when a force is applied.
 - ▶ Electrons are negative.
 - ▶ Protons are positive.

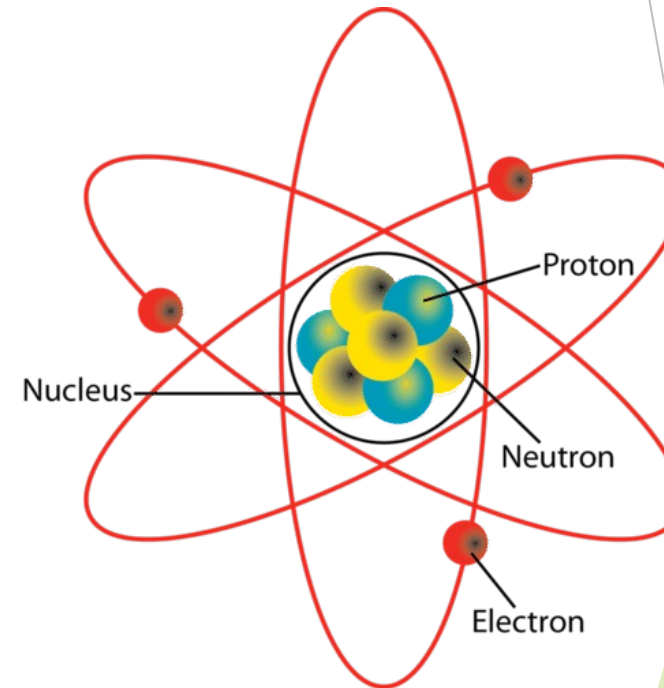

3. Technical Basics

- ▶ Static electricity is produced by moving electrons from one place to another by applying a force.
- ▶ We often see or feel the result of static electricity such as:
 - ▶ The slight electric shock when we cross a carpet or get out of a car
 - ▶ Lightning
- ▶ When two bodies are charged to different potentials there is an electric potential between the bodies
 - ▶ Like charges repel
 - ▶ Unlike charges attract

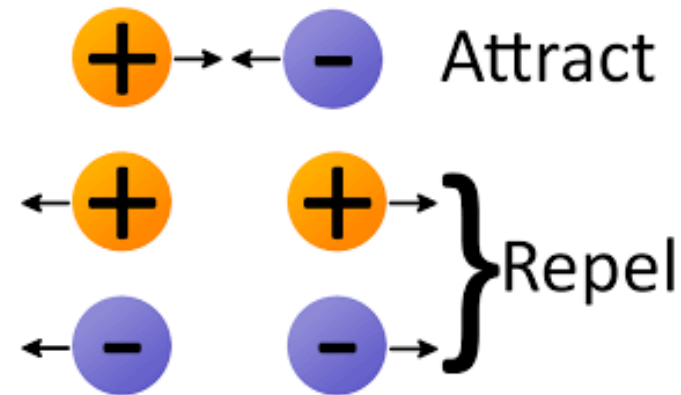



3. Technical Basics

▶ Conductors

- ▶ Metal wires that join circuits are conductors
- ▶ Most metals are good conductors in particular aluminium and copper
- ▶ A small amount of electrical pressure (voltage) can make electrons move along a conductor

▶ Insulators

- ▶ Insulators do not allow electric current to pass easily
- ▶ Insulators are plastics, dry wood, ceramic, porcelain, glass etc
- ▶ Very large electrical pressure (very high voltage) must be applied to move electrons in insulators
- ▶ These voltages usually damage the insulating material



3. Technical Basics

- ▶ The meaning of Current, its units and abbreviation
 - ▶ An electric current is an ordered movement of electrons from the negative terminal to the positive terminal of an electricity source, such as a battery.
 - ▶ The basic unit for electric current (I) is the ampere (A) - commonly shortened to amp
- ▶ The meaning of Voltage, its units and abbreviation
 - ▶ A battery produces an abundance of electrons from a chemical reaction which forces the current to flow in a circuit. This is called the Electric Potential Difference, or Electromotive Force (EMF).
 - ▶ The basic unit for EMF (E) is the volt (V) - commonly referred to as Voltage



3. Technical Basics

- ▶ The meaning of Resistance, its units and abbreviation
 - ▶ The amount of electrons that can move down a wire is dependent on how thick the wire is and how long it is.
 - ▶ The thicker the wire the lower the resistance to the electrons.
 - ▶ The longer the wire the higher the resistance to the electrons.
 - ▶ If the electrical pressure is increased more electrons can be made to flow along a given conductor. Resistance is the opposition to current flow.
 - ▶ The basic unit for Resistance (R) is the ohm (Ω) - the Greek capital letter Omega
- ▶ The meaning of Power, its units and abbreviation
 - ▶ Power is the rate at which energy is changed from one form to another or work is done.
 - ▶ The basic unit of Power (P) is the watt (W)



3. Technical Basics

Table 5 Prefixes for SI units

<i>Prefix</i>	<i>Symbol</i>	<i>Factor</i>	<i>Extended form</i>
yotta	Y	10 ²⁴	1 000 000 000 000 000 000 000 000
zetta	Z	10 ²¹	1 000 000 000 000 000 000 000
exa	E	10 ¹⁸	1 000 000 000 000 000 000
peta	P	10 ¹⁵	1 000 000 000 000 000
tera	T	10 ¹²	1 000 000 000 000
giga	G	10 ⁹	1 000 000 000
mega	M	10 ⁶	1 000 000
kilo	k	10 ³	1 000
hecto	h	10 ²	100
deca ^(a)	da	10 ¹	10
deci	d	10 ⁻¹	0.1
centi	c	10 ⁻²	0.01
milli	m	10 ⁻³	0.001
micro	μ	10 ⁻⁶	0.000 001
nano	n	10 ⁻⁹	0.000 000 001
pico	p	10 ⁻¹²	0.000 000 000 001
femto	f	10 ⁻¹⁵	0.000 000 000 000 001
atto	a	10 ⁻¹⁸	0.000 000 000 000 000 001
zepto	z	10 ⁻²¹	0.000 000 000 000 000 000 001
yocto	y	10 ⁻²⁴	0.000 000 000 000 000 000 000 001

(a) Sometimes spelt 'deka'.



3. Technical Basics

▶ Examples

- ▶ 22 kV = 22,000 V (22 kilo volts, 22 thousand volts)
- ▶ 2 mV = 0.002 V (2 milli volts, 2 thousandths of a volt)
- ▶ 22 kΩ = 22,000 Ω (22 kilo ohms, 22 thousand ohms)
- ▶ 1 MΩ = 1,000,000 Ω (1 mega ohm, 1 million ohms)
- ▶ 15 mA = 0.015 A (15 milli amps, 15 thousandths of an amp)
- ▶ 120 μA = 0.000120 A (120 micro amps, 120 millionths of an amp)

3. Technical Basics

Simple calculations



$$V = I \times R$$

$$I = \frac{V}{R}$$

$$R = \frac{V}{I}$$

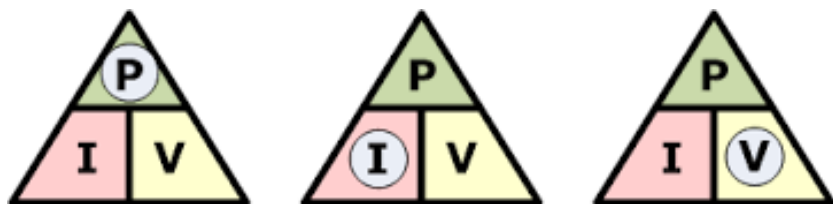

$$P = I \times V$$

$$I = \frac{P}{V}$$

$$V = \frac{P}{I}$$

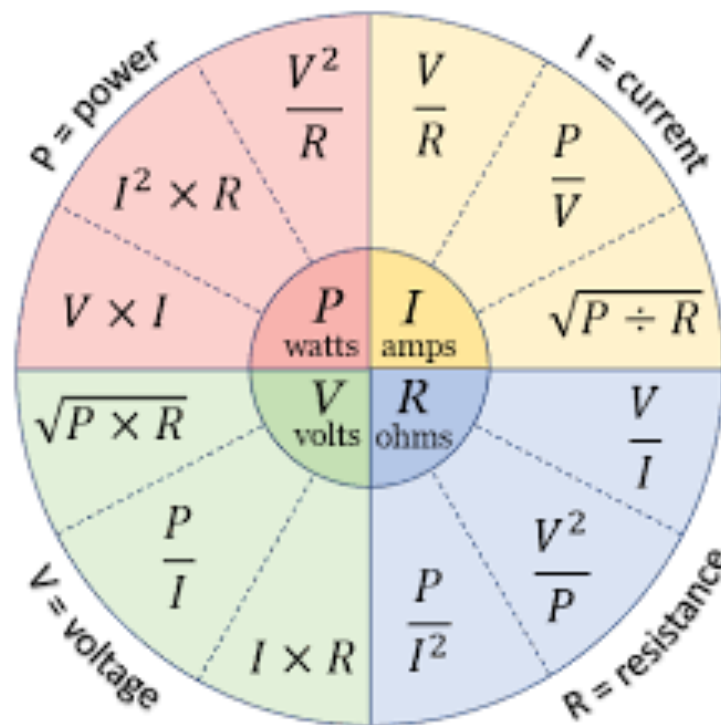

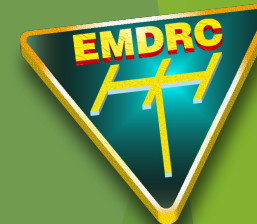

3. Technical Basics

Electrical Symbols



Antenna



Earth



Speaker



Microphone



Resistor



Lamp



Switch



Cell



Battery

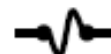

Fuse

3. Technical Basics

- ▶ Sensitive electronic circuits can be damaged by applying an excessive voltage or voltage of wrong polarity, (i.e. positive and negative swapped around).
- ▶ Simple Schematic of a torch

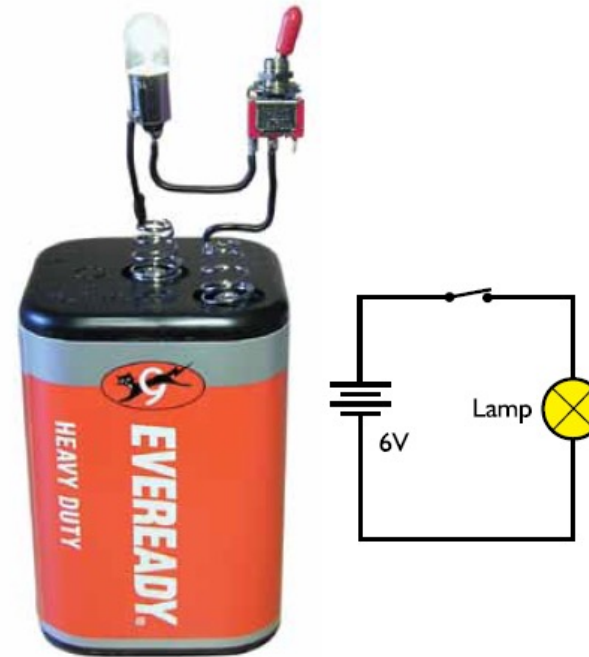

3. Technical Basics

- ▶ Meaning of DC and AC
 - ▶ Direct Current (DC) electrons flow in one direction, direct current comes from a battery.
 - ▶ Alternating Current (AC) the electrons flow in one direction stop and then flow in the other direction. Alternating current comes from an alternator and is the type of electricity that is the 230 V mains power.

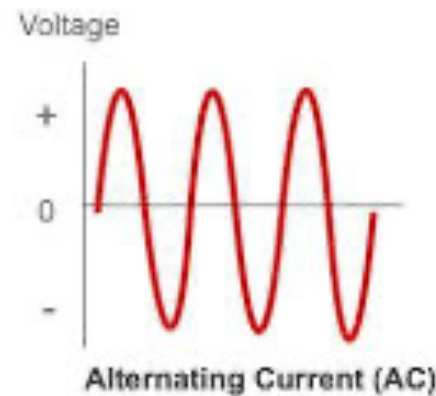
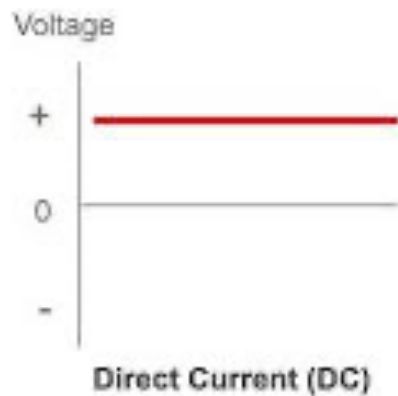



3. Technical Basics

- ▶ Frequency (F)
 - ▶ Frequency is measured in Hertz abbreviation Hz
 - ▶ Hertz is the number of cycles an Alternating Current (AC) has per second
 - ▶ The 230 volt electricity supply in Australia is 50 Hz
- ▶ Audible Frequency (AF)
 - ▶ Audible Frequency range 20 Hz to 20 kHz (top end lowers with age)
 - ▶ Voice frequency for radiotelephony 300 Hz to 3 kHz
- ▶ Radio Frequencies (RF)
 - ▶ 300 kHz to 3 MHz Medium frequency (MF)
 - ▶ 3 MHz to 30 MHz High frequency (HF)
 - ▶ 30 MHz to 300 MHz Very high frequency (VHF)
 - ▶ 300 MHz to 3,000 MHz Ultra high frequency (UHF)

3. Technical Basics

- ▶ The sine wave.
- ▶ Sine waves are produced by oscillators.
- ▶ Sine waves can be referred to by their:
 - ▶ Frequency
 - ▶ Period
 - ▶ Wavelength
 - ▶ Cycle

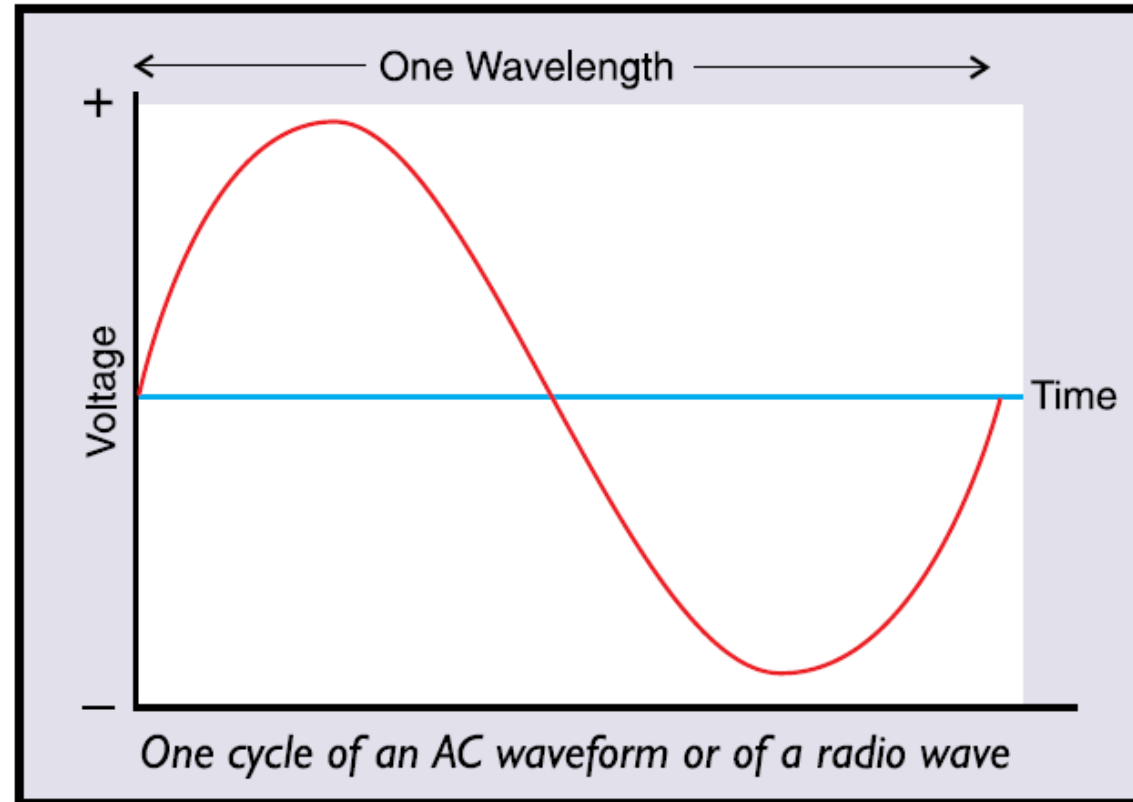

3. Technical Basics

- ▶ The relationship between frequency and wavelength
- ▶ Radio waves travel at the speed of light, abbreviation C, which is 300 million metres per second

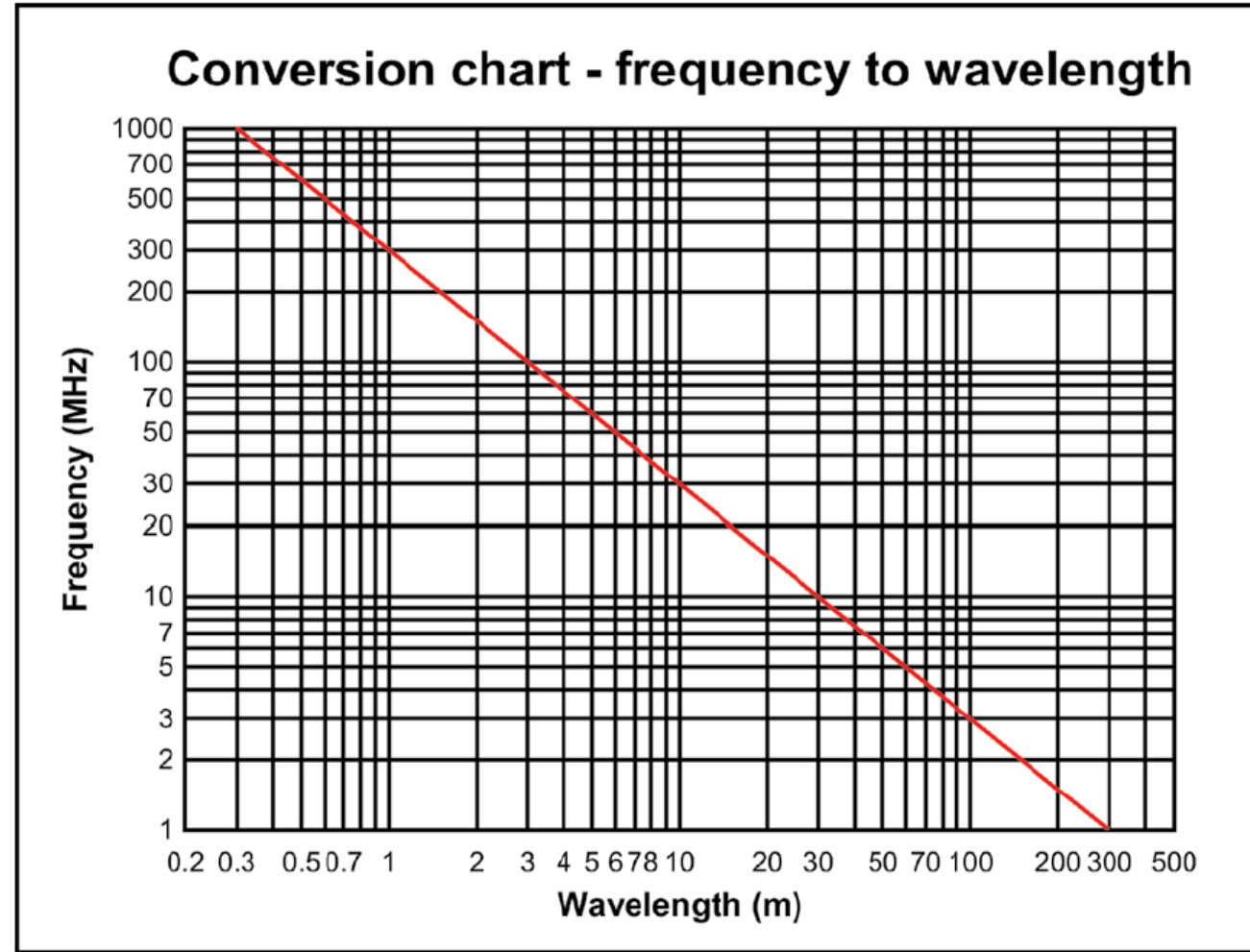



3. Technical Basics

- ▶ Electric current is:
 - ▶ A). The voltage applied to a conductor
 - ▶ B). The opposition offered to electrons in a circuit
 - ▶ C). Movement of electrons from negative to positive
 - ▶ D). The rate at which electrical energy is changed to light energy



3. Technical Basics

- ▶ Good conductors are:
 - ▶ A). Silicon and germanium
 - ▶ B). Glass and porcelain
 - ▶ C). Wood and Ceramic
 - ▶ D). Copper and Aluminium



3. Technical Basics

- ▶ If 10 volts is applied to a circuit consisting of a resistance of 5 ohms the resultant current will be:
 - ▶ A). 0.5 A
 - ▶ B). 2 A
 - ▶ C). 15 A
 - ▶ D). 20 A



3. Technical Basics

- ▶ 1000 volts is often represented as:
 - ▶ A). 1 mV
 - ▶ B). 1 MV
 - ▶ C). 1 nV
 - ▶ D). 1 kV

2/01/2021



Section 4

Transmitters and Receivers

Author: Peter Hartfield VK3PH - Version: 3-2021



4. Transmitters and Receivers

- ▶ The basis of the transmitter is the oscillator
 - ▶ The oscillator generates radio frequency energy at a specific frequency
 - ▶ The radio frequency is called the carrier
 - ▶ Turning the oscillator on and off with a key allows Morse Code to be sent

4. Transmitters and Receivers

- ▶ Block or “concept” diagrams of simple transmitters and receivers
 - ▶ Simple Morse code transmitter

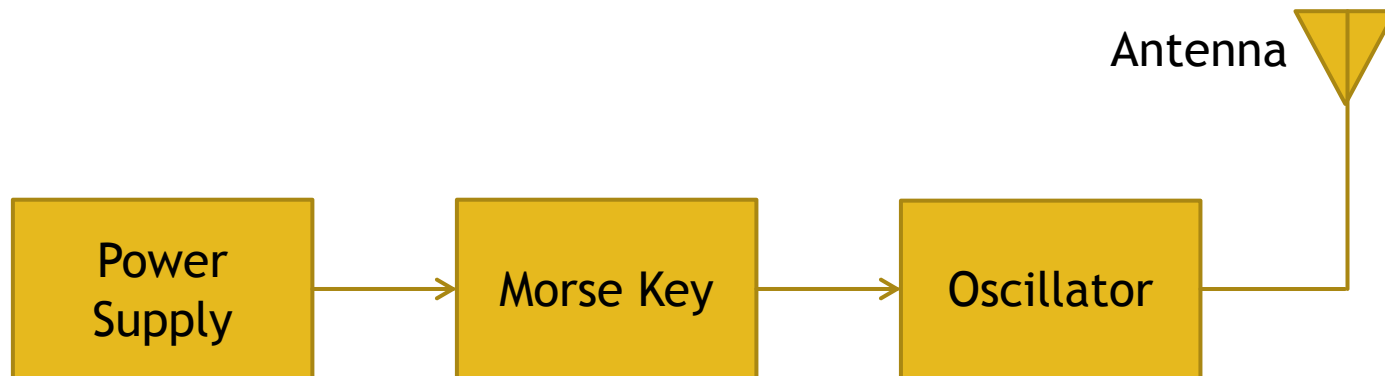

4. Transmitters and Receivers

- ▶ Block or “concept” diagrams of simple transmitters and receivers
 - ▶ Simple radio receiver

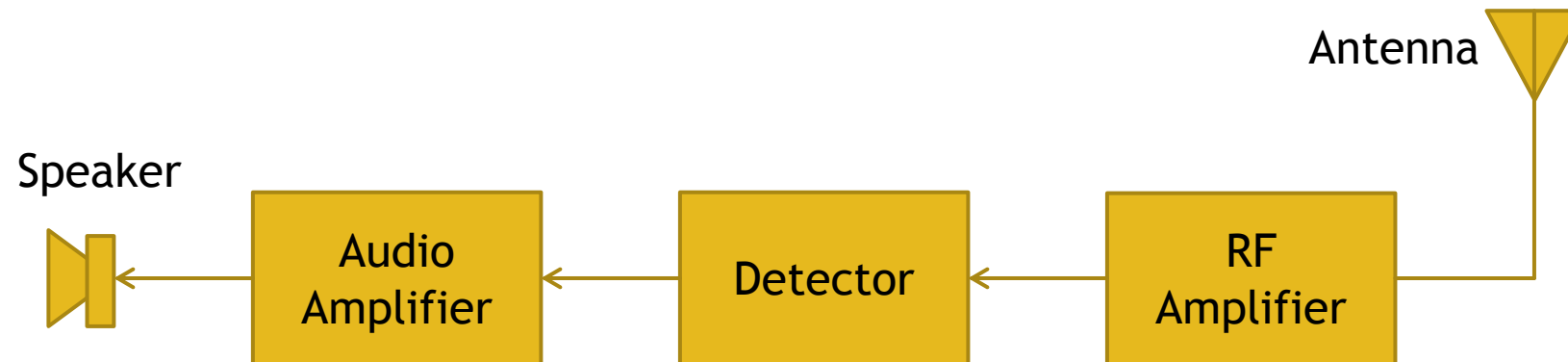

4. Transmitters and Receivers

- ▶ Block or “concept” diagrams of simple transmitters and receivers
 - ▶ Simple radio transmitter

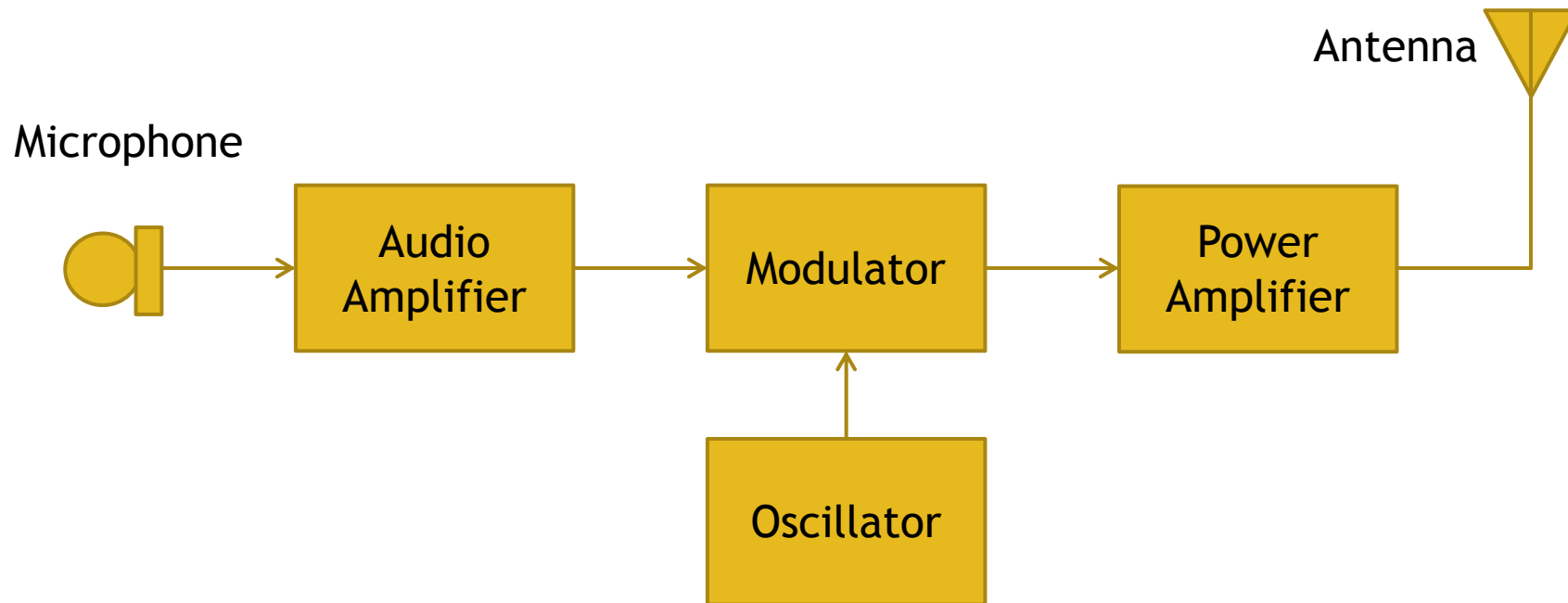

4. Transmitters and Receivers

AM

- ▶ Amplitude Modulation

FM

- ▶ Frequency Modulation

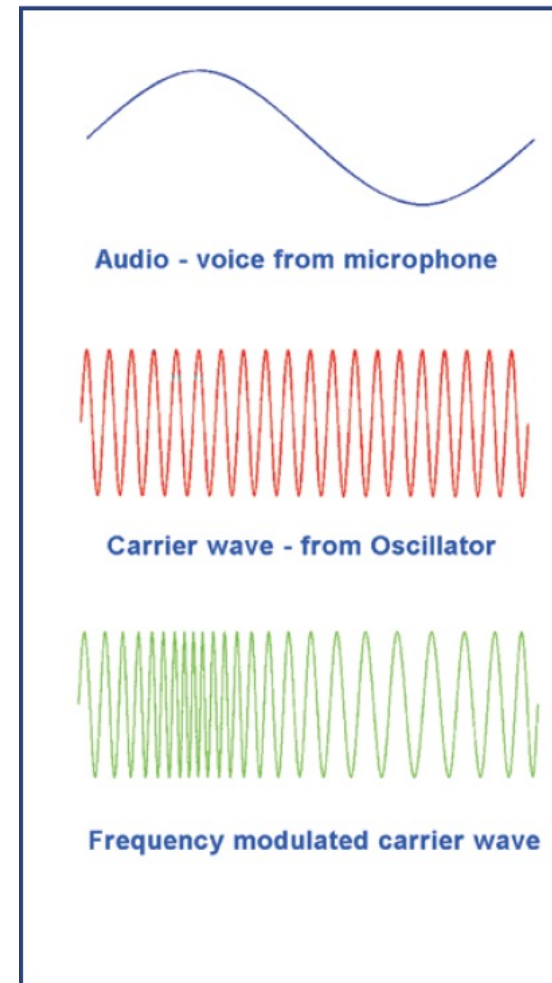
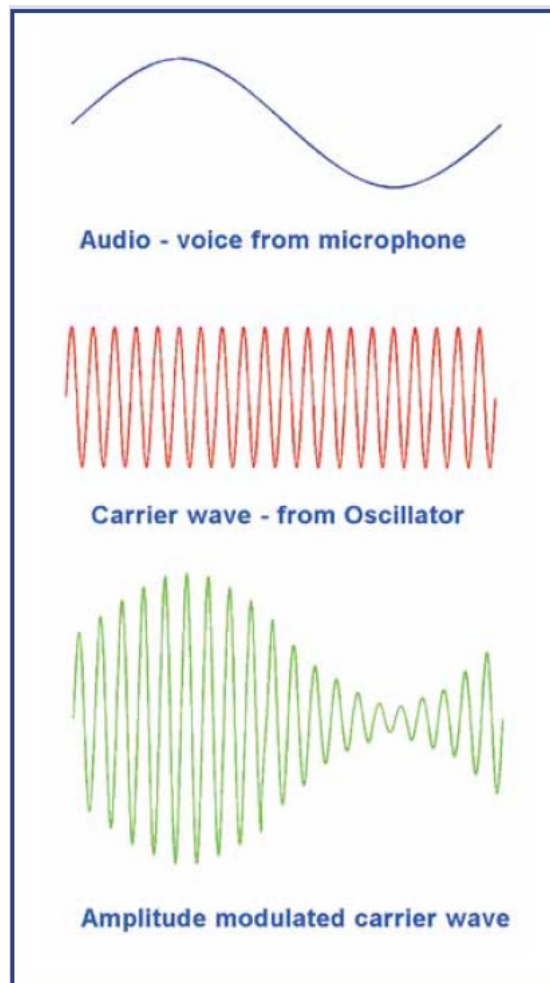



4. Transmitters and Receivers

▶ Types of Amplitude Modulation

- ▶ Single Sideband (SSB) is a form of amplitude modulation
- ▶ The power transmitted on SSB is dependent of the volume of the operators voice
- ▶ The level of the voice signal fed into the transmitter is controlled by the microphone gain control

▶ Foundation licence holders are permitted to transmit no more than 10 watts on SSB

- ▶ On SSB the voice peaks (loudest volume) should not cause the transmitter to exceed 10 watts
- ▶ This power is 10 watts peak envelope power (PEP)



4. Transmitters and Receivers

- ▶ Effects of over modulation
 - ▶ With Frequency Modulation (FM) the output power remains constant independent of voice level.
 - ▶ A 10 watt FM transmitter will transmit 10 watts at all times
 - ▶ The frequency of the carrier changes when voice signals are fed into the transmitter
 - ▶ The amount of frequency change is called deviation
 - ▶ The amount the carrier deviates is dependent on the level (volume) of the voice signal
 - ▶ The more deviation the greater the bandwidth required to transmit the signal
 - ▶ Either AM or FM carriers that are over modulated may cause distorted output and interference to adjacent frequencies



4. Transmitters and Receivers

- ▶ Importance of proper transmitter adjustment
 - ▶ Improper adjustment of a transmitter can cause harmful interference to other radiocommunications users, both inside and outside the frequency bands allocated to Amateurs
 - ▶ It is a requirement that all components of transmitter emissions must be contained within the radiofrequency bands allocated to Amateurs



4. Transmitters and Receivers

- ▶ Transmitter output matching
 - ▶ The final power amplifier stage of a transmitter must be connected to a correctly matched transmission line and antenna to avoid possible damage to the transmitter and/or cause interference to other radiocommunication services
 - ▶ More on this topic in Section 5 - Antennas and Transmission Lines



4. Transmitters and Receivers

- ▶ Transceiver controls (e.g., IC-7300 next slide)
 - ▶ **AF** (Audio Frequency) also called volume control, adjusts the audio output level
 - ▶ **RF** (Radio Frequency) or receiver gain control, adjusts the receiver gain to decrease the noise received from a nearby strong station
 - ▶ **Squelch** control enables the receiver to cut out the noise when there is no signal present
 - ▶ **VFO** (Variable Frequency Oscillator) is used to change the operating frequency
 - ▶ **RIT** (Receiver Incremental Tuning) is used to adjust the receiver frequency without changing the transmitter frequency to compensate for differences in frequencies of other stations
 - ▶ **Band** switch changes the operating band of the transceiver
 - ▶ **Carrier** control adjusts the carrier frequency in CW mode

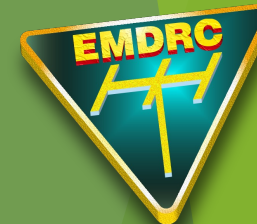

4. Transmitters and Receivers





4. Transmitters and Receivers

▶ Receiver terms

- ▶ The receiver is designed to select the required signal, detect the modulation and amplify the voice signal
- ▶ The receiver converts the voice signal back to the way it was when spoken
- ▶ A simple receiver is the tuned radio frequency receiver
- ▶ The circuit that converts the modulated signal back into audio is called a detector
- ▶ FM detectors are called discriminators



4. Transmitters and Receivers

- ▶ **Sensitivity** is the ability of the receiver to receive weak signals
- ▶ **Selectivity** is the ability of the receiver to select between stations that are close together in frequency
- ▶ **Stability** is the ability of the receiver to stay on the same frequency over long periods of time where there are significant changes in temperature



4. Transmitters and Receivers

- ▶ FM stands for:
 - ▶ A). Frequency Modulation
 - ▶ B). Fine Modulation
 - ▶ C). Forced Modulation
 - ▶ D). Flat Modulation



4. Transmitters and Receivers

- ▶ The device that generates the carrier in a transmitter is the:
 - ▶ A). Audio amplifier
 - ▶ B). Modulator
 - ▶ C). Power supply
 - ▶ D). Oscillator



4. Transmitters and Receivers

- ▶ If a transmitter is over modulated it is likely to:
 - ▶ A). Get hot
 - ▶ B). Generate FM instead of AM
 - ▶ C). Generate SSB
 - ▶ D). Cause interference



4. Transmitters and Receivers

- ▶ The ability of a receiver to receive weak signals is called the receivers:
 - ▶ A). Sensitivity
 - ▶ B). Selectivity
 - ▶ C). Stability
 - ▶ D). Super super-heterodyne

2/01/2021



Section 5

Transmission Lines and Antennas

Author: Peter Hartfield VK3PH - Version: 3-2021

65



5. Transmission Lines and Antennas

► Types of transmission lines

A range of coaxial line



RG58 50 ohm



RG213 low loss 50 ohm



*Belden 9913
ultra low loss 50 ohm*

Parallel line (Ladder line)



5. Transmission Lines and Antennas

► Coaxial connectors



Type-N plug



UHF plug



BNC plug



Type-N socket



UHF socket



BNC socket

Connectors for Coaxial Cable

5. Transmission Lines and Antennas

- ▶ Testing of transmission lines

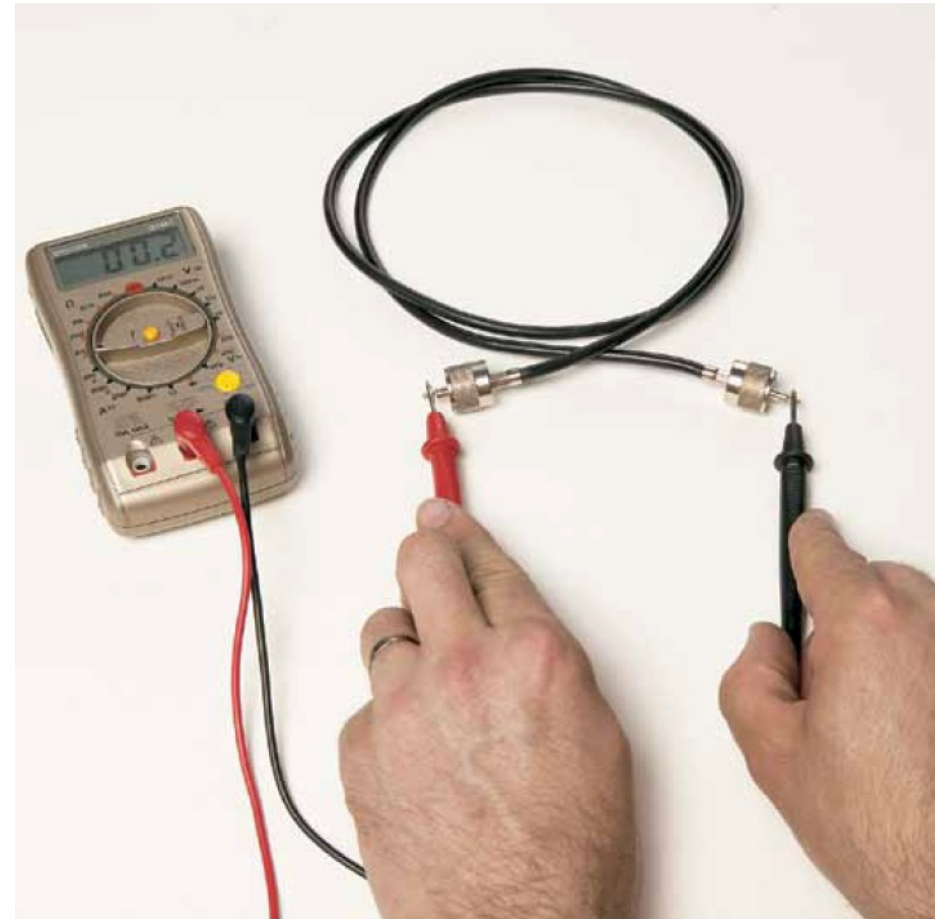

Using an ohm meter to do a continuity check on a coaxial cable



5. Transmission Lines and Antennas

▶ Transmission line

- ▶ The transmission line connects the transmitter to the antenna
- ▶ The transmission line is sometimes called a “feeder” because it feeds the radio frequency to the antenna



5. Transmission Lines and Antennas

▶ Antenna purpose

- ▶ The size of the antenna is dependent on the frequency to be transmitted
- ▶ The antenna (aerial) couples power from the transmitter to the space around the antenna
- ▶ The antenna radiates an electromagnetic wave by converting electrical signals to radio waves and vice versa
- ▶ The antenna should be resonant at the frequency to be transmitted / received
- ▶ The antenna that radiates well also receives well
- ▶ Antenna are affected by their height above ground and proximity to buildings, trees etc

5. Transmission Lines and Antennas

- ▶ The electromagnetic wave radiated from an antenna is made up of electric lines of force and magnetic lines of force
- ▶ Generally the orientation of the antenna with respect to the ground will indicate the polarisation
- ▶ Generally vertical antennas produce vertically polarised signals and horizontal antennas produce horizontally polarised signals
- ▶ Transmitter and receiver antenna should be the same polarisation for best results

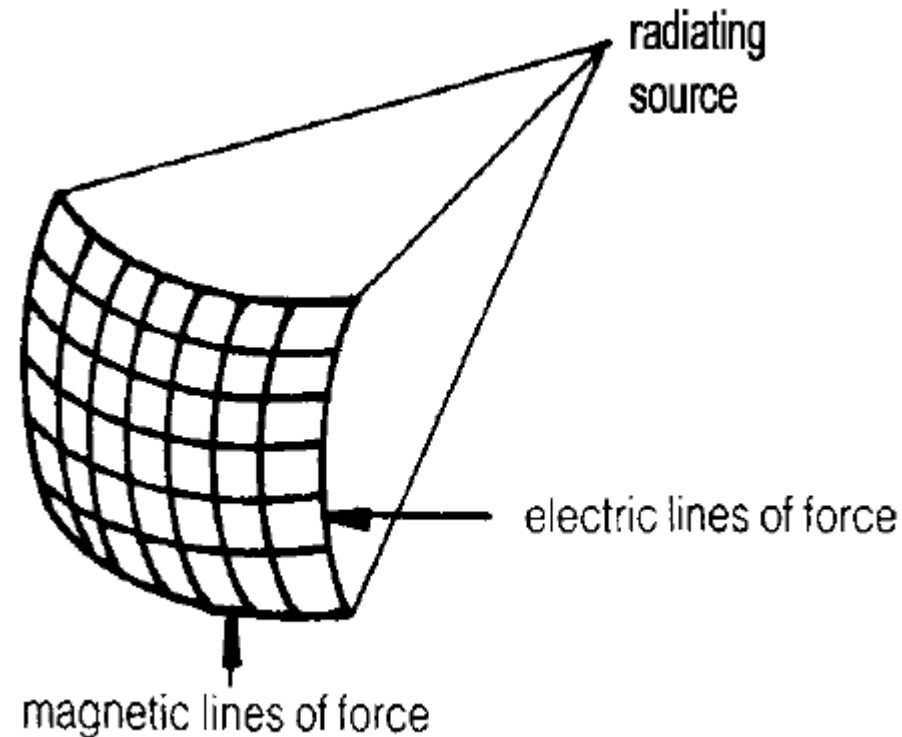

5. Transmission Lines and Antennas

- ▶ Recall the relationship between frequency and wavelength
- ▶ Therefore there is a relationship between the physical length of an antenna and the frequency of operation

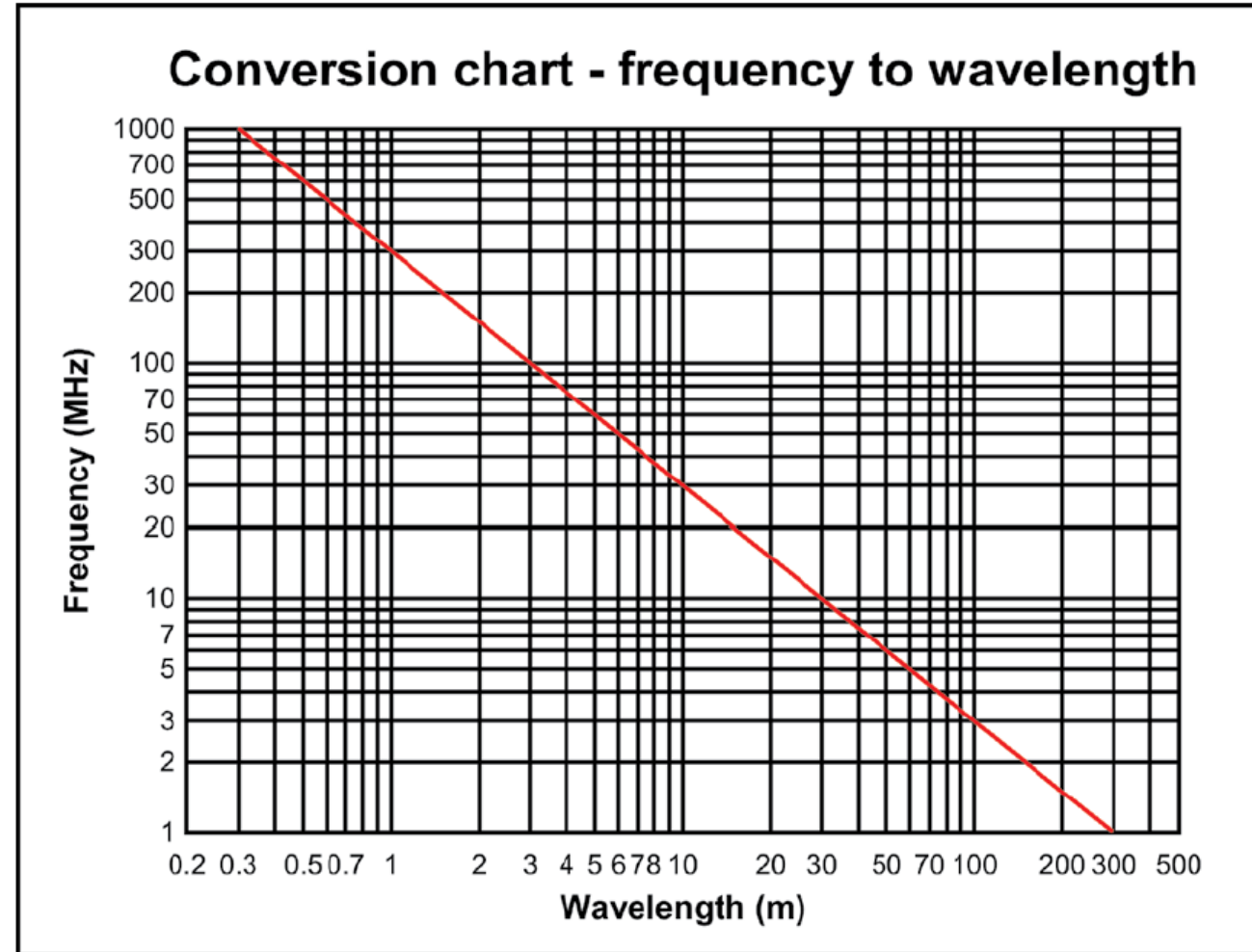



5. Transmission Lines and Antennas

- ▶ Identification of common antennas (images to follow)
 - ▶ Vertical antenna with ground plane (radials)
 - ▶ Centre fed dipole antenna
 - ▶ Yagi antenna
 - ▶ Folded dipole antenna
 - ▶ End fed wire antenna

5. Transmission Lines and Antennas

- ▶ Vertical antenna with ground plane (radials)

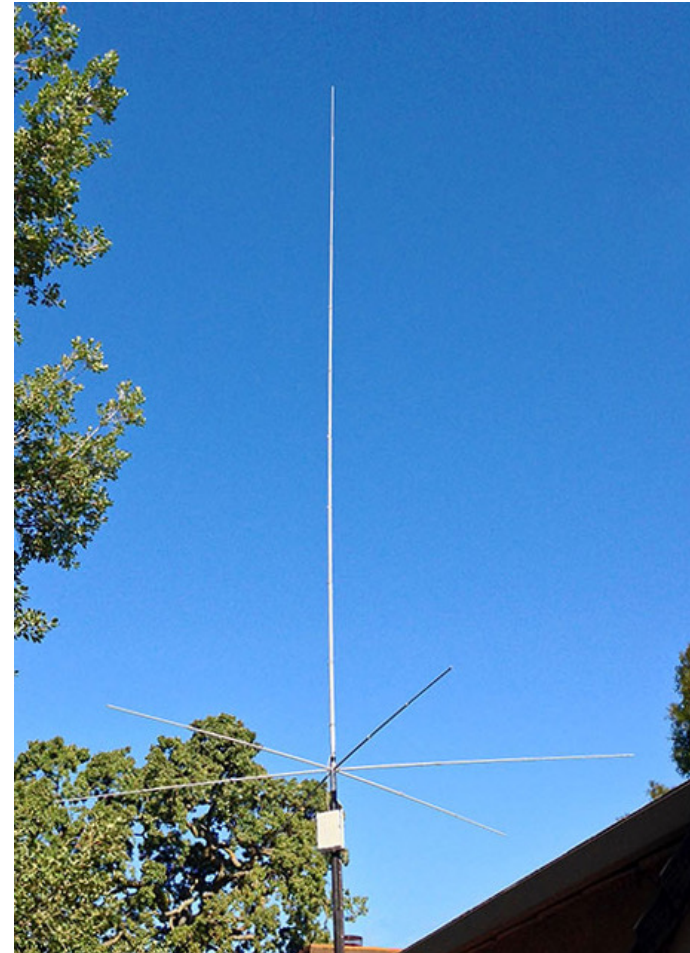
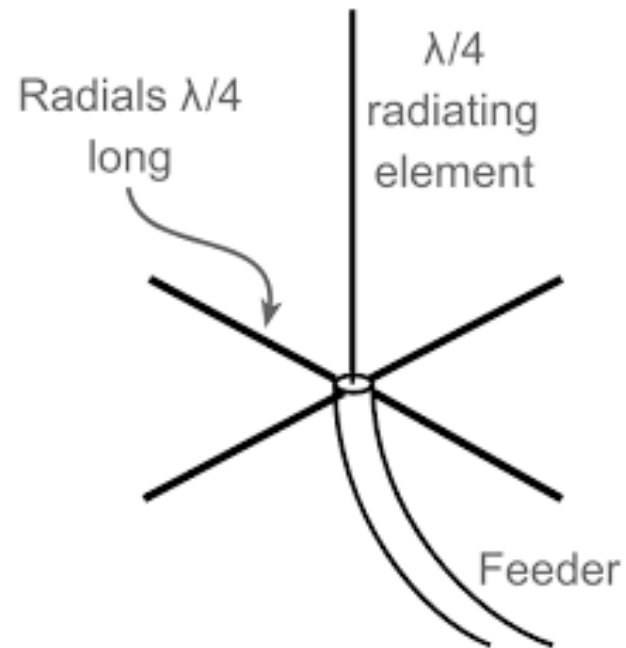

5. Transmission Lines and Antennas

► Centre fed dipole antenna

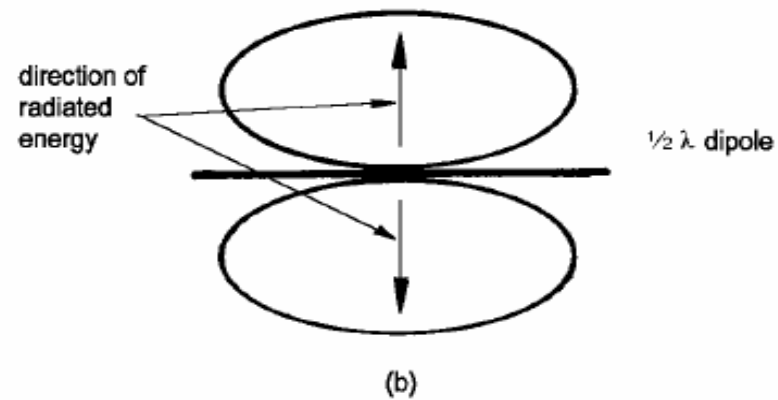
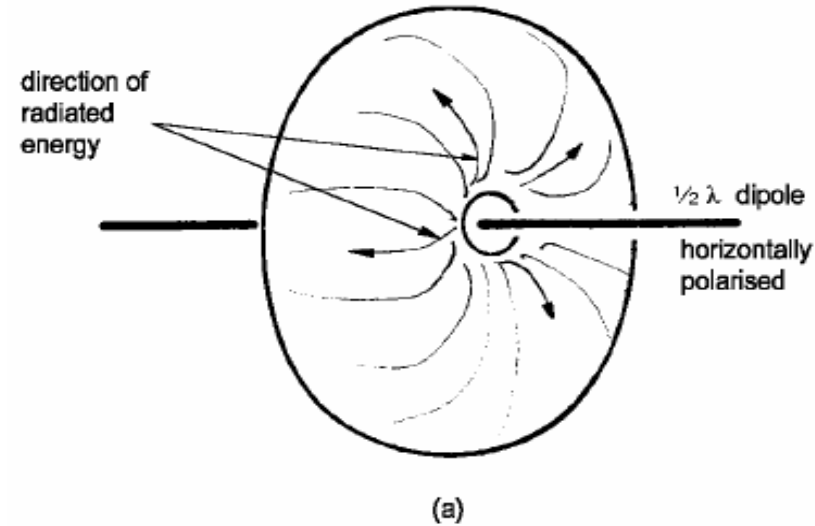
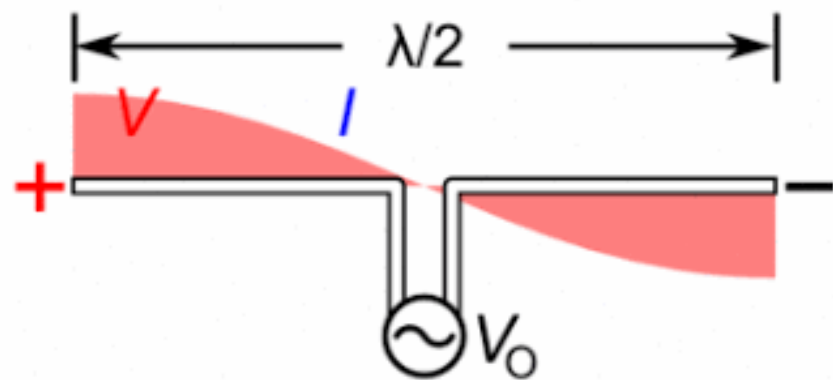
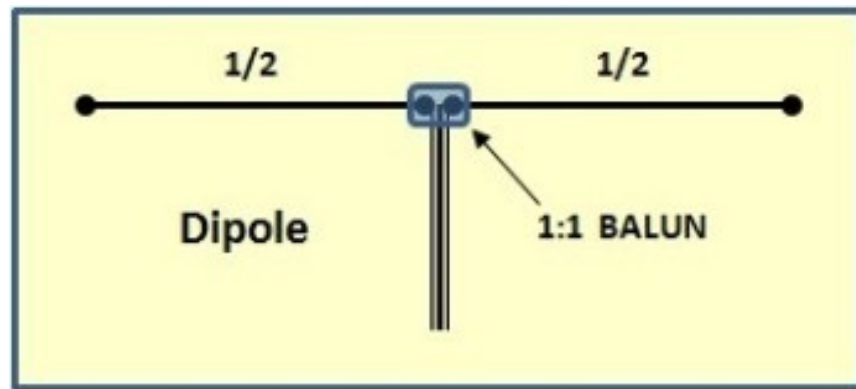

5. Transmission Lines and Antennas

Yagi Antennas





5. Transmission Lines and Antennas

▶ Effective Radiated Power (ERP)

- ▶ Antennas such as Yagi's have gain, and are unidirectional. This means the electromagnetic wave is concentrated into one direction.
- ▶ The directivity of antennas has a similar effect as using a higher powered transmitter.
- ▶ The Effective Radiated Power (ERP) of the transmitting system is increased.
- ▶ Gain of antennas is measured in decibels (dB)
 - ▶ Gain is measured relative to a dipole antenna
 - ▶ A gain of 3 dB results in twice the Effective Radiated Power

5. Transmission Lines and Antennas

- ▶ Folded dipole antenna
 - ▶ The image shows a pair of VHF folded dipole antennas

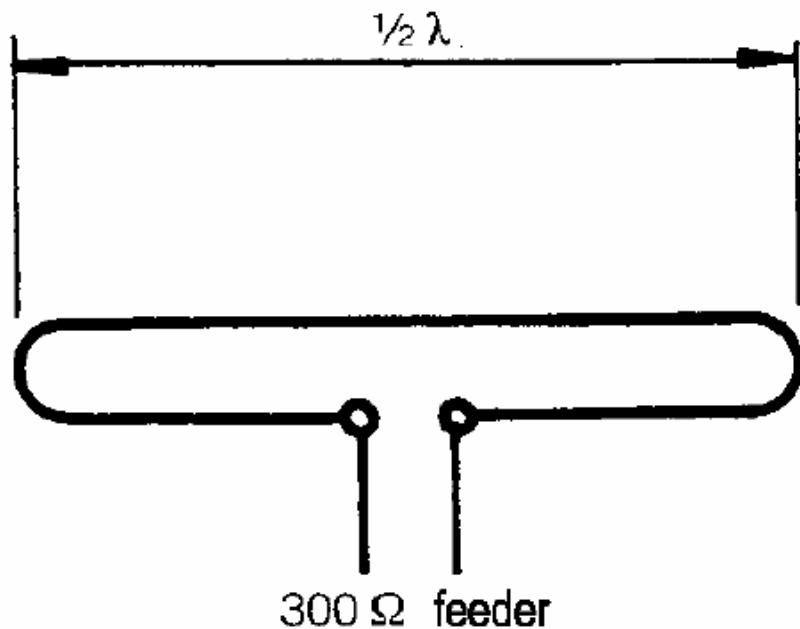

5. Transmission Lines and Antennas

- ▶ End fed wire antennas are usually fed with open wire transmission line and require an antenna tuning unit to match the antenna to the output of the transmitter.

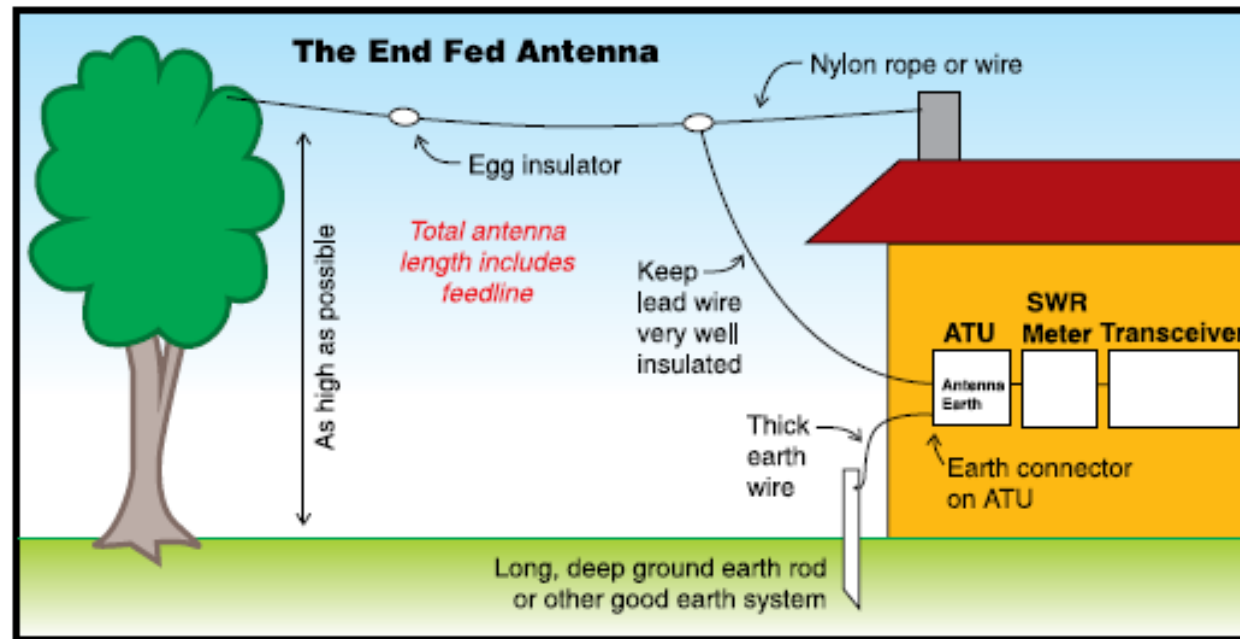

5. Transmission Lines and Antennas

- ▶ The on-air performance of an amateur station can be improved significantly by the correct choice of antenna.
 - ▶ Vertical - when you need to access a repeater, on a vehicle, limited space etc.
 - ▶ Dipole - use on HF bands, horizontal, easy to construct etc.
 - ▶ Yagi - when you need gain (low power), determine direction of signal etc.
 - ▶ Folded Dipole - often used for VHF / UHF, driven element of a Yagi etc.
 - ▶ End Fed Antenna - lower HF bands, access to a tuner etc.

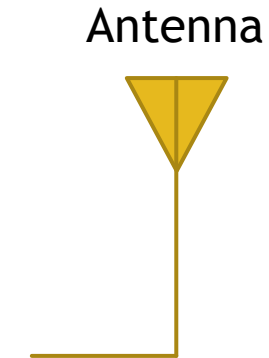



5. Transmission Lines and Antennas

- ▶ Antenna matching
 - ▶ Antenna impedance is measured in ohms.
 - ▶ Impedance can be considered AC resistance.
 - ▶ Most modern transmitting equipment has an output impedance of 50 or 75 ohms.
 - ▶ The output impedance of the transmitter should be matched (have the same impedance) as the transmission line and the antenna.
 - ▶ Mismatched transmitter outputs, transmission line and antenna will cause power to be reflected back and forth along the transmission line.
 - ▶ The reflected wave is called a standing wave.

5. Transmission Lines and Antennas

- ▶ Standing Wave Ratio (SWR)
 - ▶ A Standing Wave Ratio (SWR) meter is used to measure how well the antenna system is matched.
 - ▶ An SWR meter is connected between the output of the transmitter and the antenna
 - ▶ The SWR should be checked each time you change frequency
 - ▶ Checking the SWR on a transmission line using an SWR meter is a component of the practical for the Foundation Licence

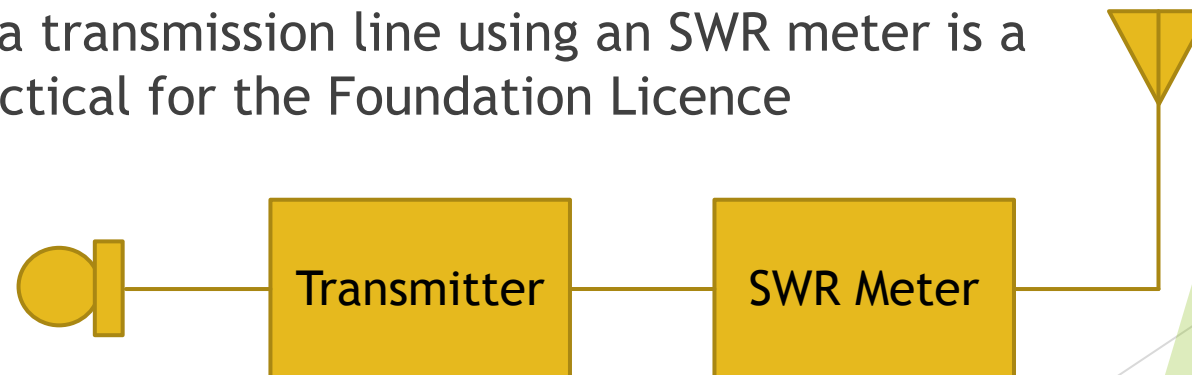

5. Transmission Lines and Antennas

▶ Standing Wave Ratio (SWR)

- ▶ Checking SWR allows for the adjustment of your antenna to bring the antenna closer to resonance by lengthening or shortening the antenna
- ▶ An SWR of more than 2:1 is likely to indicate a fault in the antenna system
- ▶ A good SWR on an antenna system is 1.5:1 or less
- ▶ An SWR greater than 1.5:1 may indicate the antenna needs tuning or a fault condition is developing

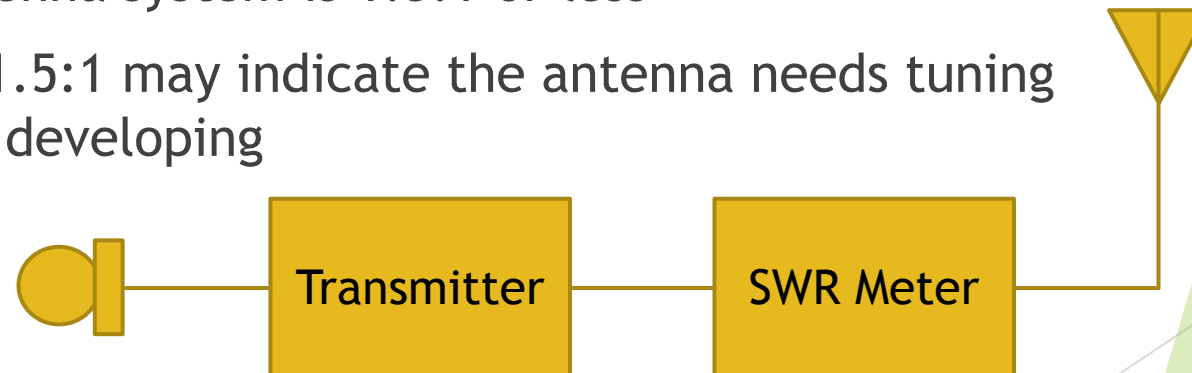

5. Transmission Lines and Antennas

▶ Antenna Tuning Unit (ATU)

- ▶ An Antenna Tuning Unit (ATU) sometimes called a TRANSMATCH can be used to provide the correct operating impedance for the transmitter.
- ▶ The ATU tunes the antenna system allowing operation on multiple bands using the one antenna.
- ▶ Adjusting the ATU is not a requirement for the practical component of the Foundation Licence but knowing its purpose and location between the transmitter output and the antenna is a requirement.

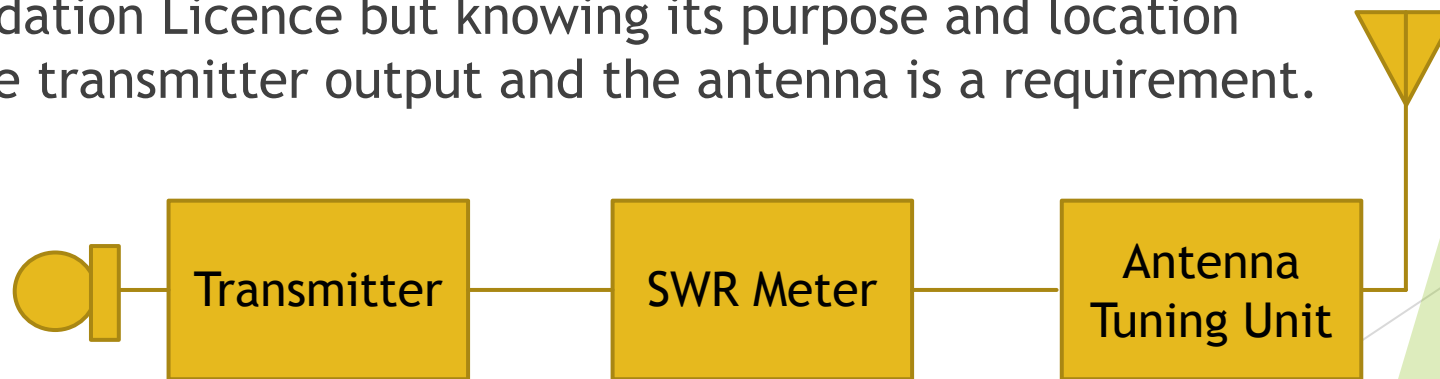

5. Transmission Lines and Antennas

Balun (Balanced to unbalanced)

- ▶ The balun is a type of transformer that can connect a balanced antenna to an unbalanced transmission line.
- ▶ The balun can also be used to match impedances of transmission lines and antennas.

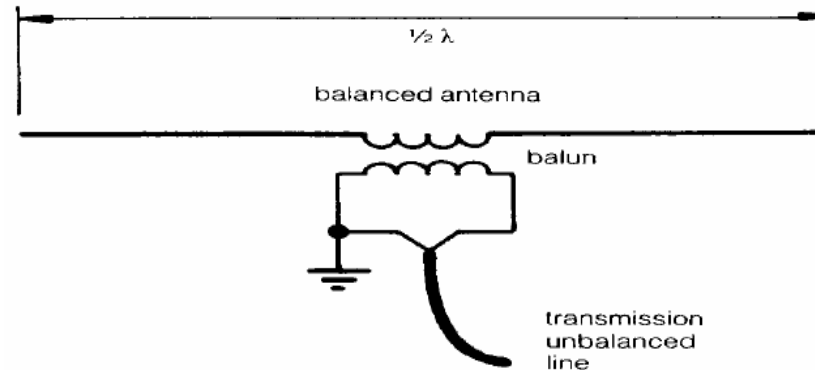
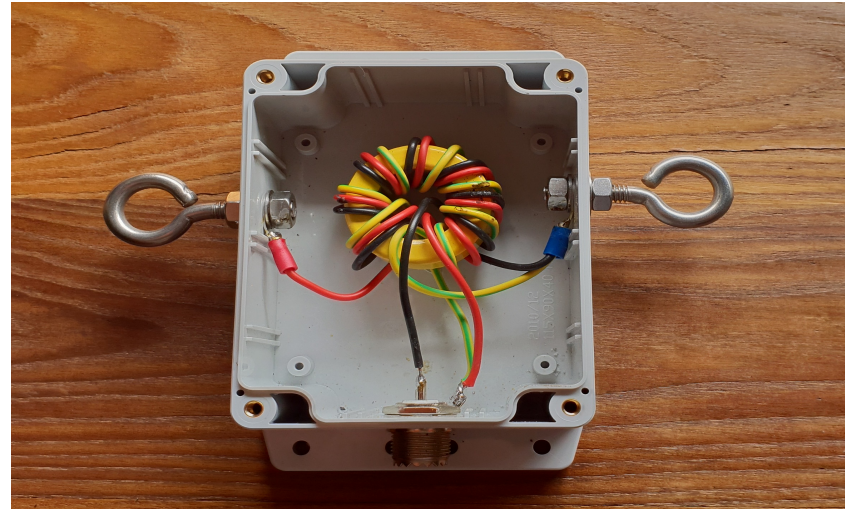

5. Transmission Lines and Antennas

- ▶ Testing transmitters
 - ▶ A dummy load is a resistor typically the same output impedance as the transmitter i.e. 50 ohms
 - ▶ The dummy load allows the transmitter to be tested with minimal radiation i.e. not tested “on air” via the antenna.
 - ▶ The dummy load also allows the output power of the transmitter to be adjusted.
 - ▶ The power for SSB is 10 watts PEP. For CW, FM and AM average power is not to exceed 10 watts.
 - ▶ Some power meters can be very inaccurate. Care must be taken in the selection of a power meter to measure output power.





5. Transmission Lines and Antennas

- ▶ The purpose of an antenna is to:
 - ▶ A). Let people know you are a radio amateur
 - ▶ B). Provide a convenient place for birds to land
 - ▶ C). Allow balanced transmission lines to be used
 - ▶ D). Convert electrical signals into radio waves and visa versa.



5. Transmission Lines and Antennas

- ▶ The longer the antenna:
 - ▶ A). The higher the frequency of operation
 - ▶ B). The lower the frequency of operation
 - ▶ C). The better the antenna will work
 - ▶ D). The more vertical polarisation will be obtained



5. Transmission Lines and Antennas

- ▶ The reason the antenna and transmission line are matched in impedance to the transmitter output is to:
 - ▶ A). Increase the SWR
 - ▶ B). Eliminate the use of a dummy load
 - ▶ C). Keep SWR to a minimum
 - ▶ D). Keep the transmitted power to 10 watts.



5. Transmission Lines and Antennas

- ▶ An antenna with a 3 dB gain operating with at 10 watt transmitter will result in an effective radiated power (ERP) of:
 - ▶ A). 3 watts
 - ▶ B). 10 watts
 - ▶ C). 20 watts
 - ▶ D). 30 watts

2/01/2021



Section 6

Propagation

Author: Peter Hartfield VK3PH - Version: 3-2021

91





6. Propagation

▶ Propagation basics

- ▶ Radio waves are electromagnetic waves. How these waves travel from the transmitting antenna to the receiving antenna is called propagation.
- ▶ Radio waves travel in straight lines although they can be reflected, refracted or diffracted.
- ▶ The further the radio wave gets from the transmitting antenna the weaker it becomes.
- ▶ Any time a radio wave travels through anything other than “free space” it will travel slower and lose strength.

6. Propagation

- ▶ Effect of obstacles and structures on VHF and UHF signals
 - ▶ VHF, UHF and frequencies above UHF are dependent on an almost clear line of sight path from transmitter to receiver.
 - ▶ VHF and UHF are generally obstructed by hills and other large structures.
 - ▶ VHF and UHF signals can be bent or diffracted over some obstacles.
 - ▶ Temperature changes in the troposphere results in ducts that can cause VHF and UHF signals to be propagated over long distances.

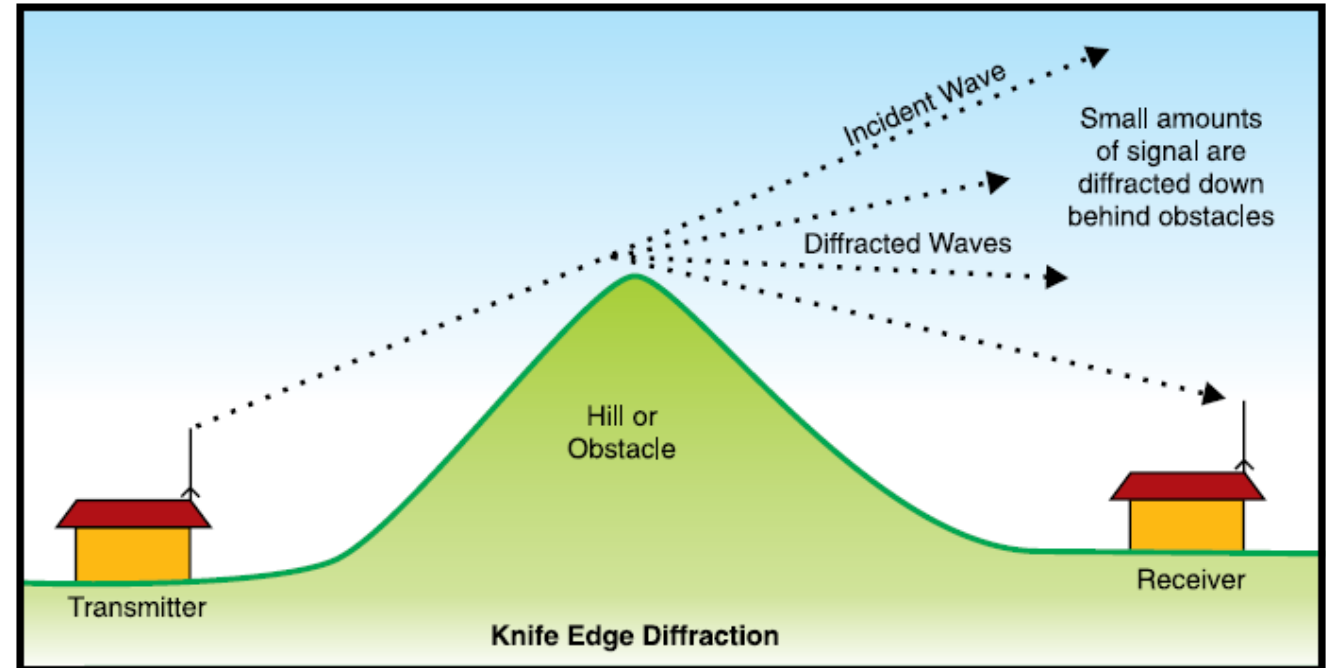

6. Propagation

- ▶ Long distance communications on VHF and UHF

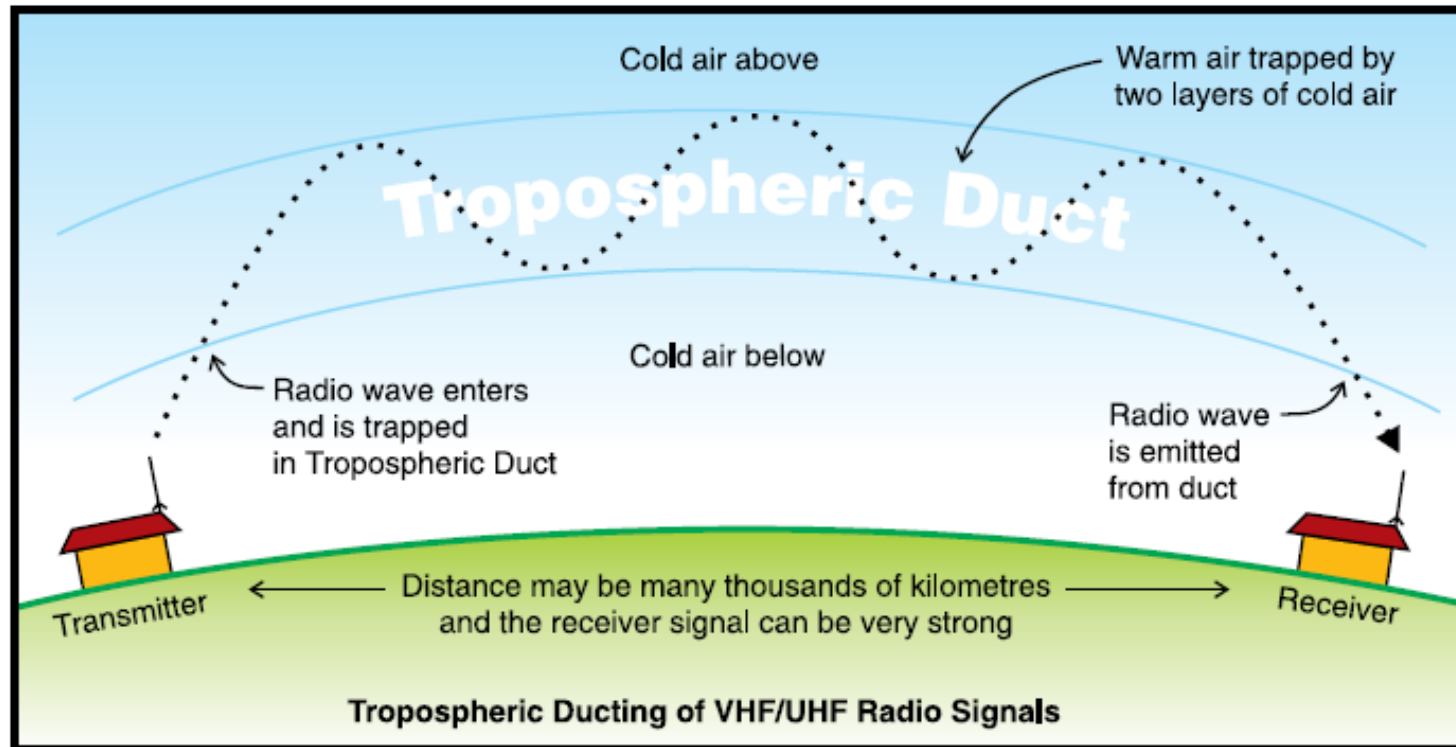

VHF and UHF radio waves can be caught in a tropospheric duct caused by a heat inversion layer in the lower atmosphere, (the troposphere).

6. Propagation

▶ The Ionosphere

- ▶ The height of the ionospheric layers is approximate
- ▶ The sun ionises or charges the air particles
- ▶ When radio waves hit the ionosphere they can be bent back to earth
- ▶ The bending is dependent on the layer, its density and the frequency of operation

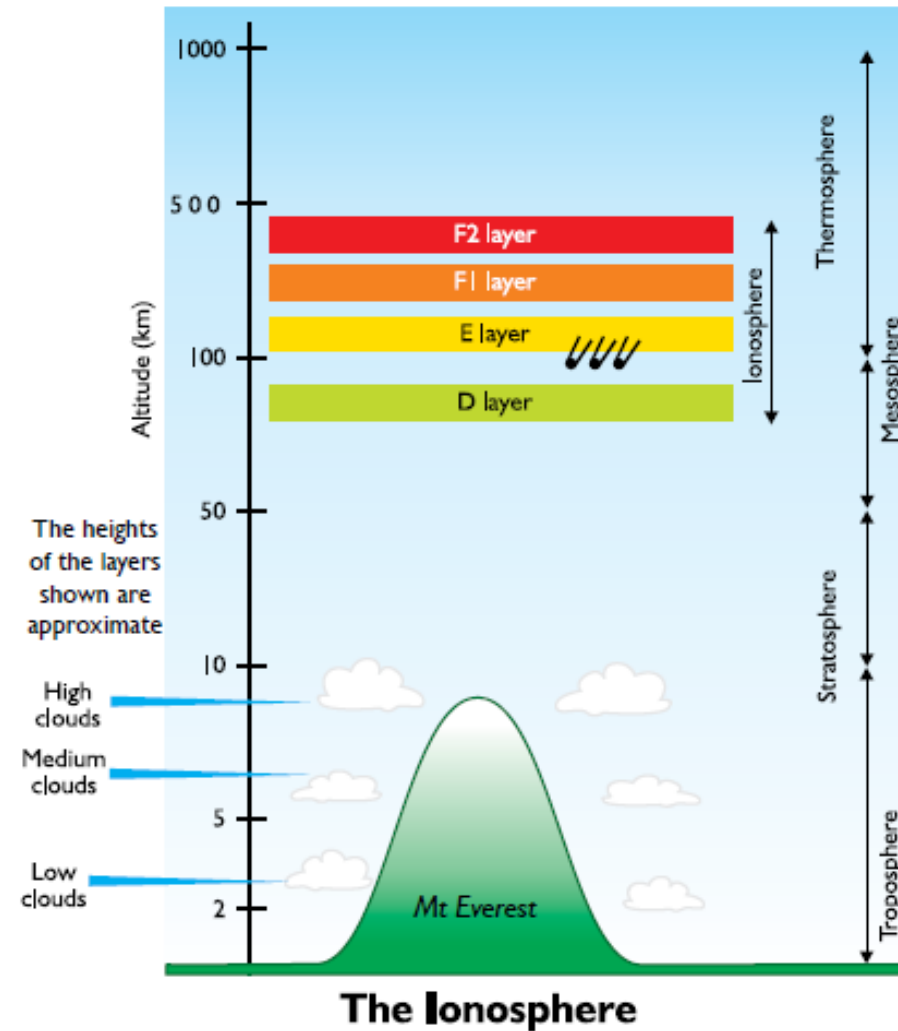

6. Propagation

- ▶ Factors effecting HF propagation
 - ▶ The ionosphere refracts the radio wave
 - ▶ The amount of refraction is dependent on:
 - ▶ Sun spot activity
 - ▶ Time of day
 - ▶ The season
 - ▶ The ionosphere is reliant on ultraviolet radiation from the sun
 - ▶ Sunspots are in an 11 year cycle

ISES Solar Cycle Sunspot Number Progression

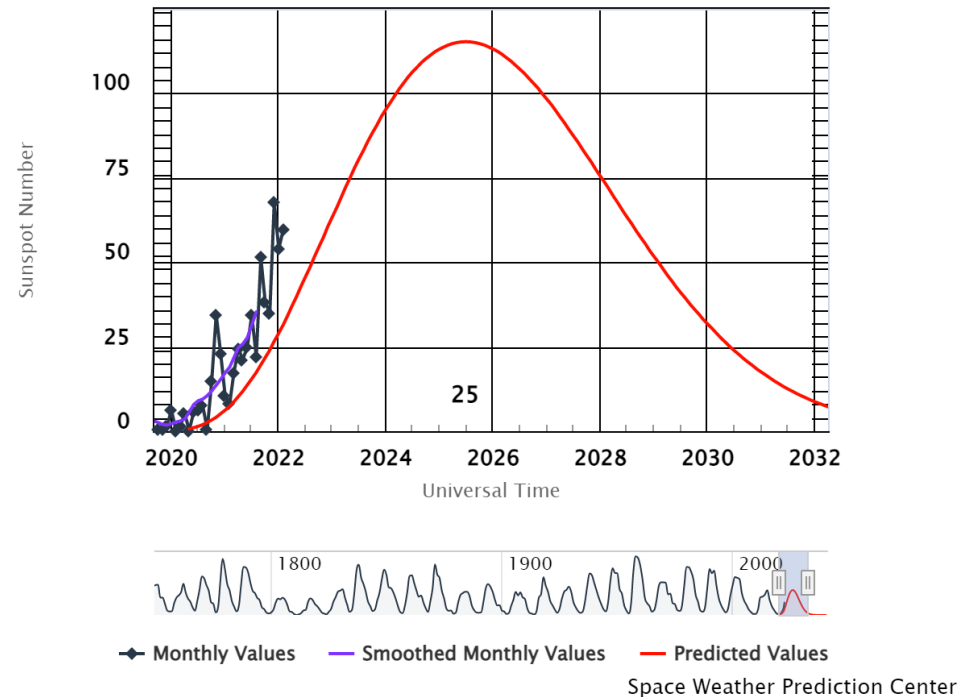

6. Propagation

► Ionospheric refraction

- A signal travelling from the transmitter to the receiver via two paths can cause multipath fading
- Selective fading occurs when the frequency components that make up the signal are refracted by different amounts

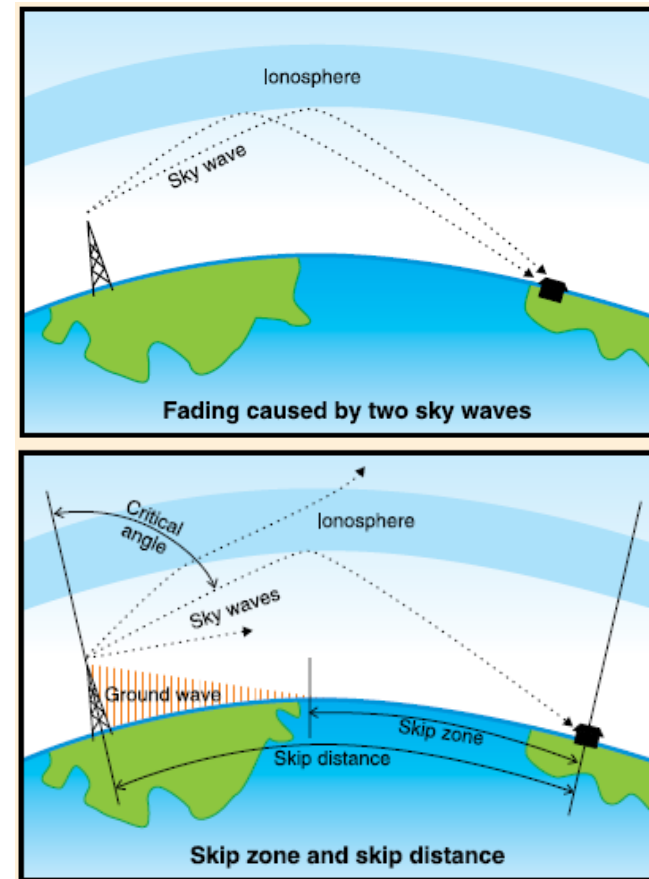



6. Propagation

- ▶ As a radio wave is radiated from the antenna. As the wave travels further it becomes:
 - ▶ A). Stronger
 - ▶ B). Weaker
 - ▶ C). Ionised
 - ▶ D). Ducted



6. Propagation

- ▶ Long distance HF propagation is a result of:
 - ▶ A). Ground wave
 - ▶ B). Knife edge diffraction
 - ▶ C). Tropospheric ducting
 - ▶ D). Ionospheric refraction



6. Propagation

- ▶ VHF and UHF signals can be obstructed by:
 - ▶ A). Large obstacles
 - ▶ B). Transmission during night time
 - ▶ C). Strong north winds
 - ▶ D). Transmission over water



6. Propagation

- ▶ VHF and UHF long distance communication is possible mainly due to:
 - ▶ A). Magnetosphere conditions
 - ▶ B). Atmospheric conditions
 - ▶ C). F1 or F2 layer ionisation
 - ▶ D). VHF or UHF waves skipping off the upper atmosphere



Section 7

Interference





7. Interference

- ▶ There are many sources of potential RF noise generation that can interfere with broadcast radio and television receivers. These sources of man made noise include:
 - ▶ Power tools, Computers, Arc Welders, Power lines etc.
- ▶ Interference can be caused to:
 - ▶ Telephones - mobile and fixed, Television, Radio reception,
 - ▶ Audio equipment, Computers, Vehicle electronic equipment, Blasting devices
- ▶ There are sources of natural noise that can cause interference such as lightning, electrostatic build build-up etc.



7. Interference

- ▶ Sources of radio interference
 - ▶ Amateur stations can cause interference to other radio communication services and television services.
 - ▶ The cause of the interference from an amateur station is often as a result of incorrect operation of amateur transmitting equipment.
 - ▶ Potential reasons for interference from an amateur station is:
 - ▶ Over modulation - excessive microphone gain
 - ▶ Incorrectly tuned antennas - high SWR
 - ▶ Breakthrough on FM or SSB - close proximity of transmit antenna to receiving antenna
 - ▶ Mains fed interference - signals fed by the 230 volt mains supply



7. Interference

- ▶ Interference can generally be resolved by introducing technical solutions, however these can be complex and a qualified person should be sought to resolve these problems.
- ▶ Electronic equipment can operate within an electromagnetic field without interference. This is called Electromagnetic Compatibility (EMC) or radio frequency immunity.
- ▶ EMC issues are likely to cause neighbourhood disputes. To resolve a dispute:
 - ▶ Discuss the problem with the person concerned, obtain dates and times of interference
 - ▶ Try and identify the source of interference
 - ▶ Understand the need for diplomacy
 - ▶ Seek advice and where necessary involve the ACMA



7. Interference

- ▶ Interference as a result of EMC issues is dependent on:
 - ▶ Transmitted power
 - ▶ Frequency of operation
 - ▶ Type of emission from the transmitter i.e. AM, SSB, FM etc
 - ▶ Distance the transmitter is from the affected equipment - selection and location of antennas can significantly reduce the likelihood of interference.

7. Interference

► Filters

- Filters can be used to reduce the likelihood of interference
- Other filters can be used in the power supply or interconnections between the equipment
- Filters must be fitted as close to the affected device as possible

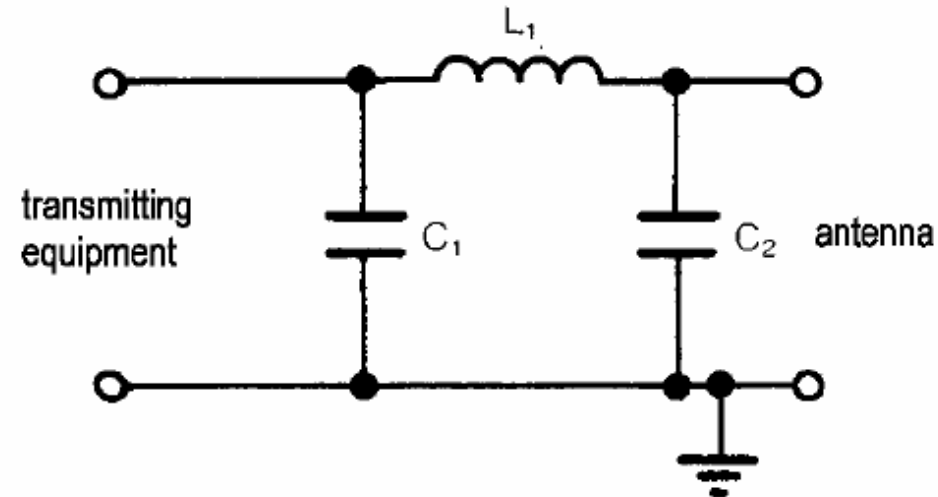

Low pass filter in the output of a transmitter, or an ATU as a filter

7. Interference

- ▶ Simple “choke” filter
 - ▶ Ferrite rods with wire wound onto them can be used to make effective RF filters
 - ▶ These filters are sometimes call coils or chokes
- ▶ Toroids can also be used as RF filters
 - ▶ For the practical you will be required to make an RF filter using a toroid or a ferrite rod
 - ▶ The RF is blocked by the filter

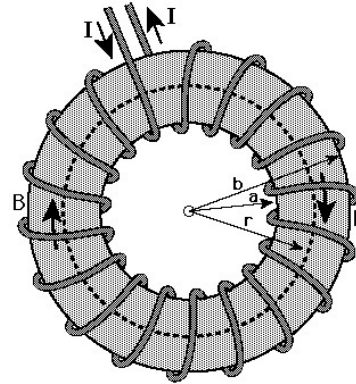

EMI suppressor and ferrite rod



Speaker wire wound around ferrite rod



Speaker wire through EMI suppressor

7. Interference

▶ Radio Frequency Earthing

- ▶ An RF earth connection in an amateur station is to provide a path to minimise RF ground currents entering the mains earth system and causing interference
- ▶ Note the earth symbol

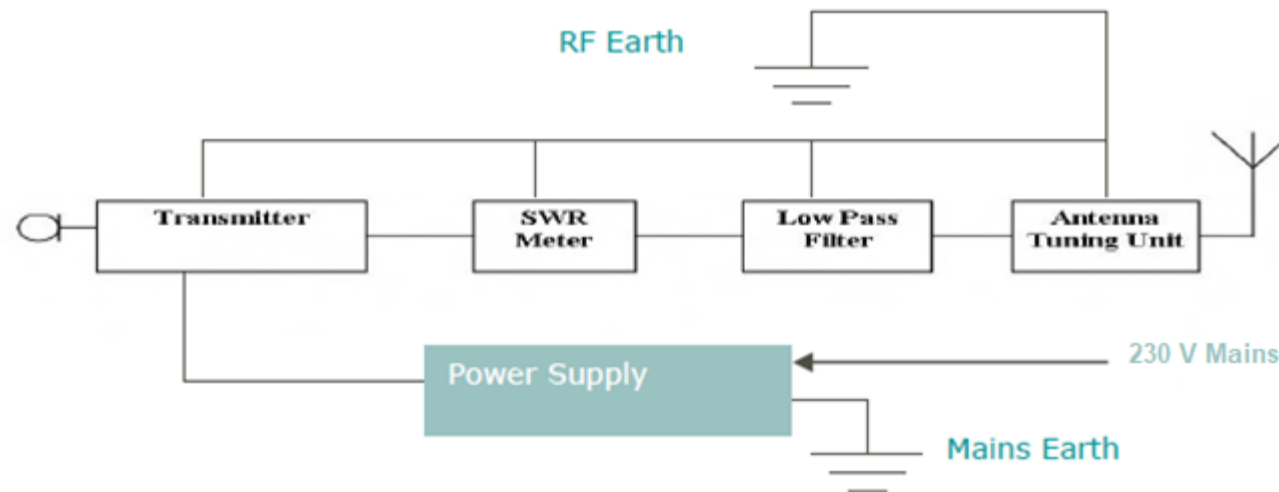



7. Interference

- ▶ Harmful Interference
 - ▶ Harmful interference is when interference is caused to a licenced radio communication service and may effect navigation beacons, emergency services etc.
 - ▶ Interference to domestic TV and radio is not considered harmful but is objectionable.
- ▶ An amateur station must not cause harmful interference to radio communications including:
 - ▶ Other users
 - ▶ Other services
- ▶ It may be necessary to shut down your station for a time to identify the interference source but this is not mandatory, unless the interference is deemed to be harmful, in which case transmission must cease until the problem is resolved.



7. Interference

- ▶ EMC problems are dependent on four factors; transmitted power, frequency and type of emission the fourth is:
 - ▶ A). Brand of radio transmitter
 - ▶ B). Weather
 - ▶ C). Distance from the affected equipment
 - ▶ D). Sun spot cycle



7. Interference

- ▶ Objectionable interference from your amateur station to domestic television reception can vary with:
 - ▶ A). The zodiac cycle
 - ▶ B). The solar cycle
 - ▶ C). Weather
 - ▶ D). Mode of operation



7. Interference

- ▶ Interference to domestic equipment may be reduced by:
 - ▶ A). Changing the transmission mode
 - ▶ B). Overmodulating the transmitter
 - ▶ C). Reducing your receivers RF gain control
 - ▶ D). Waiting until after dark to transmit when the D layer has dispersed



7. Interference

- ▶ Your amateur station is causing harmful interference to other radio services, you must:
 - ▶ A). Stop transmitting until the problem is resolved
 - ▶ B). Transmit during the hours that the affected station is off air
 - ▶ C). Contact ACMA and tell them that they have a problem
 - ▶ D). Advise the affected station that you have a licence to transmit and they should contact ACMA



7. Interference

- ▶ One way interference can be fed into nearby electronic equipment via:
 - ▶ A). The 230 volt mains
 - ▶ B). Moist atmosphere
 - ▶ C). PVC gas pipes
 - ▶ D). RF chokes wound on toroids



7. Interference

- ▶ Interference resulting in EMC problems can be minimised by:
 - ▶ A). Only using dipoles
 - ▶ B). Using vertically polarised antennas
 - ▶ C). Careful selection and locating of antennas
 - ▶ D). Only operating from a base station



7. Interference

- ▶ Interference resulting in EMC problems can be minimised by:
 - ▶ A). Operating at different times of the day or night
 - ▶ B). Reducing power and increasing the distance between the transmitter and affected equipment
 - ▶ C). Changing from lower to upper sideband on 80 m
 - ▶ D). Reducing power and reducing the distance between the transmitter and the affected equipment



2/01/2021



Section 8

Operating Practices and Procedures

Author: Peter Hartfield VK3PH - Version: 3-2021

118

8 Operating Practices and Procedures

Demonstrate connecting a transmitter/receiver safely to a power supply, microphone, transmission line and antenna

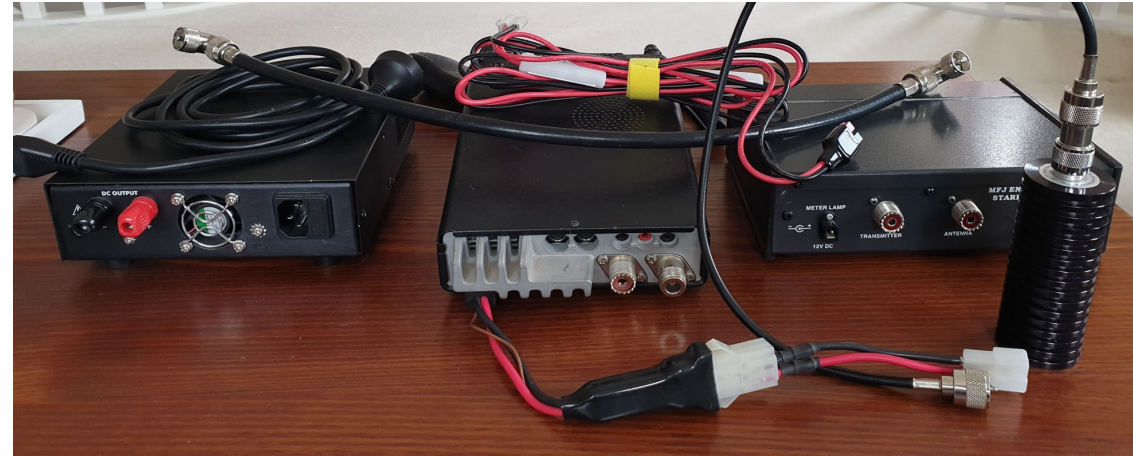



8 Operating Practices and Procedures

- ▶ Knowledge of the frequencies and emissions that may be used under a Foundation licence

3.500 MHz–3.700 MHz	Amplitude Modulation (AM) Single Side Band (SSB) Hand Keyed Morse code (CW)
7.000 MHz–7.300 MHz	
21.000 MHz–21.450 MHz	
28.000 MHz–29.700 MHz	Amplitude Modulation (AM) Single Side Band (SSB) Frequency Modulation (FM) Hand Keyed Morse code (CW)
144.000 MHz–148.000 MHz	
430.000 MHz–450.000 MHz	



8 Operating Practices and Procedures

- ▶ Requirement not to transmit on frequencies in use
 - ▶ Recall and demonstrate the requirement to listen on a frequency before transmitting to ensure that interference will not be caused to other stations using the frequency.



8 Operating Practices and Procedures

▶ Operating practices

- ▶ CQ CQ CQ this is VK3XXX VK3XXX VK3XXX over
- ▶ VK3XXX this is VK3YYY over
- ▶ This is VK3XXX listening over
- ▶ VK3YYY VK3YYY VK3YYY this is VK3XXX VK3XXX VK3XXX over
- ▶ This is VK3XXX is this frequency in use over
- ▶ VK3YYY this is VK3XXX your signal report is 5 and 9 over
- ▶ RST = Readability Strength Tone (CW)
- ▶ Signal strengths above 9 are: +10 dB etc.

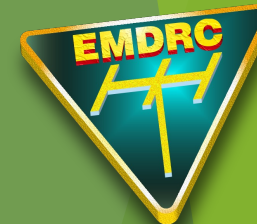

8 Operating Practices and Procedures

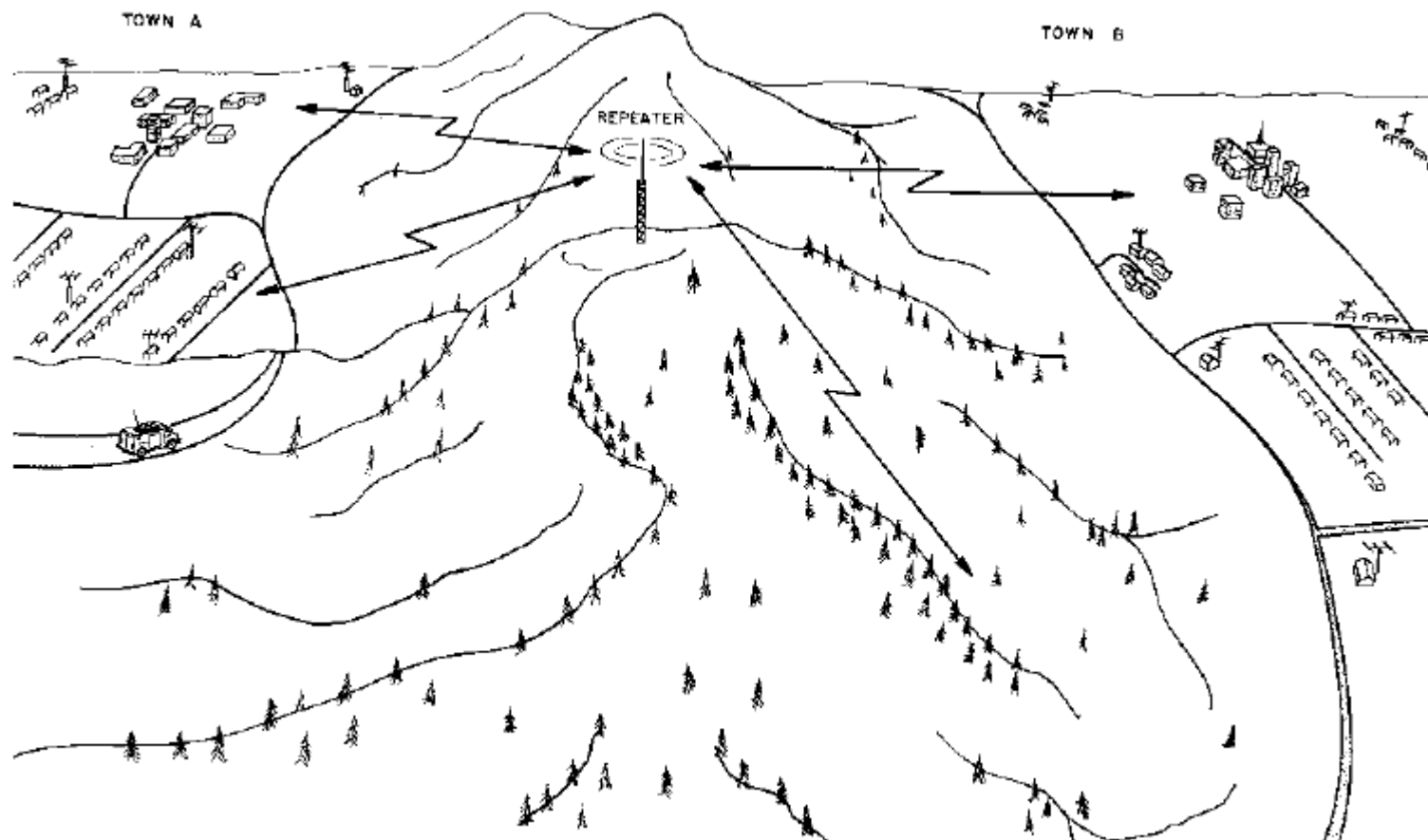



8 Operating Practices and Procedures

- ▶ Operating through a repeater
 - ▶ Explain the use of Continuous Tone Coded Squelch System (CTCSS) to access a repeater
 - ▶ This system is designed to reduce annoying signals and will assist in masking co co-channel interference
 - ▶ A tone is transmitted each time the press to talk button is pressed that is detected in the receiver and allows the mute (or squelch) to open.
 - ▶ The tone is in the 67 to 257 Hz range and often referred to as a sub-audible tone



8 Operating Practices and Procedures

- ▶ Operating through a repeater
 - ▶ Explain the use of Dual Tone Multiple Frequency (DTMF) access control systems
 - ▶ DTMF is used for telephone signalling over a medium such as a telephone line or radio link
 - ▶ DTMF is the signal produced by your mobile phone keypad
 - ▶ Two voice frequency tones of different frequencies are transmitted simultaneously
 - ▶ Often used to switch on or off and control remote equipment.



8 Operating Practices and Procedures

- ▶ Operating through a repeater
 - ▶ Explain the need to leave adequate breaks between transmissions
 - ▶ Allows other traffic to break in
 - ▶ Allows access for emergency traffic



8 Operating Practices and Procedures

- ▶ Making a “CQ” call and changing to a working frequency
 - ▶ Listen for a free frequency (say 145.600 MHz)
 - ▶ “This is VK3XXX is this frequency in use over”
 - ▶ Change back to the previous operating frequency
 - ▶ “VK3YYY this is VK3XXX please QSY to 145.600 over”
 - ▶ VK3XXX this is VK3YYY QSY to 145.600 over
 - ▶ Change frequency to 145.600 MHz
 - ▶ “VK3YYY this is VK3XXX are you on frequency over”
 - ▶ VK3XXX this is VK3YYY I hear you load and clear over



8 Operating Practices and Procedures

► Abbreviations

Q Codes

QRA	The name of my station is ...	QRO	Increase power.	QSB	Your signals are fading.
QRG	Your exact frequency (or that of ..) is ... kHz.	QRP	Decrease power.	QSK	I can hear you between my signals; break in on my transmission.
QRH	Your frequency varies.	QRQ	Send faster (... words per minute).	QSL	I am acknowledging receipt.
QRI	The tone of your transmission is (1 = Good; 2 = Variable 3 = Bad).	QRS	Send more slowly (... words per minute).	QSO	I can communicate with ... direct (or by relay through ...).
QRK	The intelligibility of your signals is (1 = Bad; 2=Poor;3 = Fair; 4 =Good; 5 = Excellent).	QRT	Stop sending.	QSP	I will relay to ...
QRL	I am busy. Please do not interfere.	QRU	I have nothing for you.	QSX	I am listening to ... on ... kHz.
QRM	Your transmission is being interfered with ... (1 = Nil; 2 = Slightly; 3 = Moderately; 4 = Severely; 5 = Extremely).	QRV	I am ready.	QSY	Change to transmission on another frequency (or on ... kHz).
QRN	I am troubled by static ... (1 = Nil; 2 = Slightly; 3 = Moderately; 4 = Severely; 5 = Extremely).	QRW	Please inform ... that I am calling on ... kHz.	QSZ	Send each word or group twice
		QRX	I will call you again at... hours (on ... kHz).	QTC	I have ... messages for you (or for ...)
		QRZ	Who is calling me?	QTH	My location is ... (QTHR is location as per Callbook).
		QSA	The strength of your signals is ... (1 = Scarcely perceptible; 2 = Weak; 3 = Fairly good; 4 = Good; 5 = Very good).	QTR	The time is ...

8 Operating Practices and Procedures

► Transmitter measurements





Section 9

Safety

9. Safety

- ▶ Dangerous voltages





9. Safety

- ▶ The dangers in amateur radio include:
 - ▶ High voltages
 - ▶ High currents
 - ▶ Electromagnetic fields
 - ▶ High sound levels
 - ▶ Working at heights
 - ▶ Working with chemicals

9. Safety

- ▶ Electrical safety - equipment to be approved





9. Safety

- ▶ Awareness of State Electricity Authority requirements
 - ▶ Approved mains operated appliances in Australia will have a manufacturers label
 - ▶ All states have regulations for maintenance of mains operated equipment and the requirements in relation to the qualifications of those who can work on such equipment.
 - ▶ <https://esv.vic.gov.au/about-esv/legislation-and-regulations/legislation-administered-by-esv/>





9. Safety

▶ Electrical Earthing

- ▶ The Australian 230 volt mains system has an earth (ground) to protect against electric shock, short circuits and faults.
- ▶ The earth wire is usually green / yellow or green in some older installations.
- ▶ The protective earth shall never be removed other than by a qualified electrician.
- ▶ Power supplies have a protective earth via a standard 3 pin plug.
- ▶ Some power supplies such as plug packs are double insulated and the earth pin is not connected.
- ▶ Never connect earths to gas pipes.



9. Safety

- ▶ Always be Aware of Safety
 - ▶ 12 mA of current can kill
 - ▶ 230 v mains can provide the voltage and current to electrocute a person
 - ▶ Vacuum tube equipment will have high voltages present
 - ▶ Always treat the circuit as if it is live
 - ▶ Never remove the covers from any equipment
 - ▶ Beware of old equipment, it may not be up to current safety standards
 - ▶ Look up and live when installing antennas
 - ▶ Never remove an earth from a piece of equipment
 - ▶ Always replace fuses with exactly the same type and rating of fuse, as per the manufacturers specifications



9. Safety

▶ Fuses

- ▶ Fuses are to protect from high currents
- ▶ Fuses have a predetermined current melt and open the circuit
- ▶ High currents can burn
- ▶ Replacement fuses must always be the same type and current rating as per the manufacturers specifications
- ▶ Earth leakage breakers are sensitive to fault conditions and will trip
- ▶ Most often installed in switchboards



9. Safety

- ▶ Station layout for physical safety
 - ▶ The layout of an Amateur station should take account of physical safety issues.
 - ▶ Recall that trailing cables are trip hazards and dangerous.
 - ▶ Covers should be installed on all operational equipment.
 - ▶ Fire extinguishers should be of the appropriate type (i.e. suitable for electrical fires).

9. Safety

- ▶ Power lead safety
 - ▶ Frayed or damaged power leads are dangerous and should be replaced or repaired by an Authorised person.
 - ▶ Never overload, piggy back or daisy chain power boards.

9. Safety

- ▶ Know location and desirability of a Mains OFF switch



9. Safety

- ▶ Actions to be taken in the event of an accident involving electricity
 - ▶ Switch off or remove from the power
- ▶ Electric Shock
 - ▶ A casualty of electric shock must not be touched unless the power has been switched off





9. Safety

- ▶ Call for help - use of resuscitation techniques

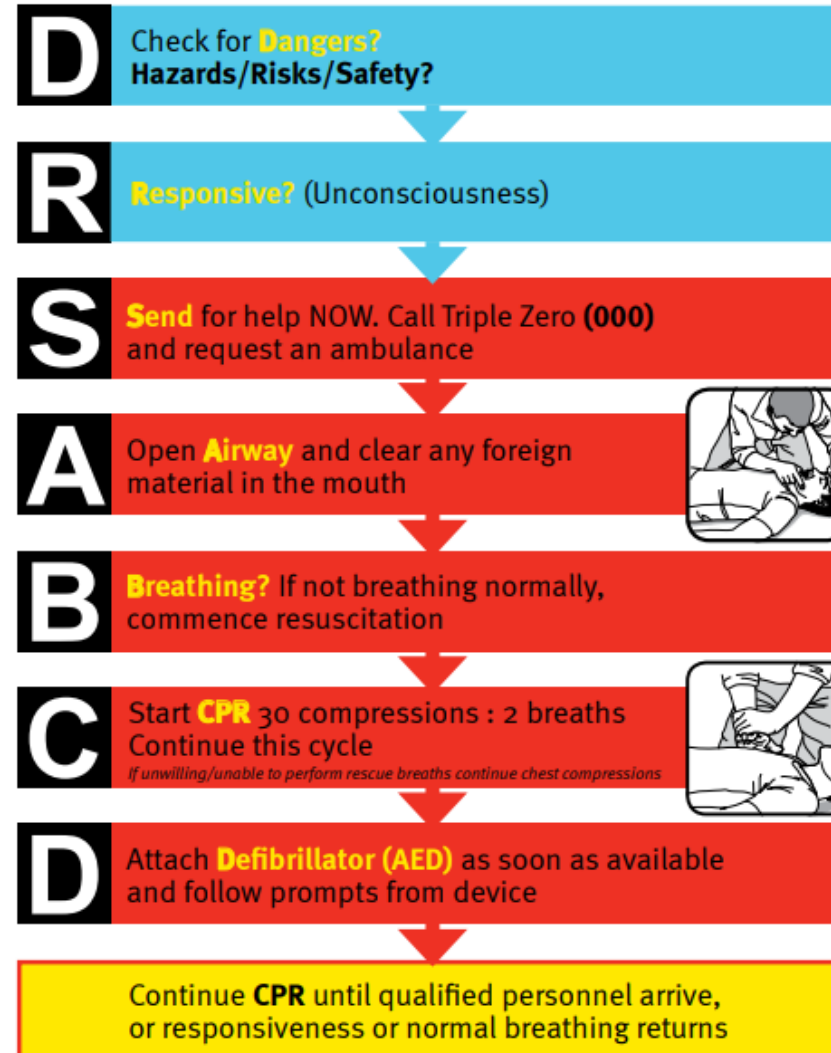



9. Safety

▶ Battery safety

- ▶ Some batteries have toxic or corrosive chemicals or produce gases
- ▶ Never short circuit a battery
- ▶ Never dispose of a battery in a fire
- ▶ Use protective fuses with batteries
- ▶ Children should not play with batteries



9. Safety

▶ Antennas and safety

- ▶ Electromagnetic radiation may be harmful if concentrated into a narrow beam of very high power
- ▶ Electromagnetic radiation may burn or heat parts of the human body or organs
- ▶ Keep distance between you and electromagnetic radiation



9. Safety

- ▶ Antenna erection is potentially dangerous and should be carried out by suitably experienced persons.
- ▶ Antennas and their fittings must be suitably located and secured and must never be connected to, or sited close to, mains poles and lines.
- ▶ It is good practice to install lightning protection on antennas, disconnect antennas from any radio equipment prior to a thunderstorm and never operate during a thunderstorm.

9. Safety

- ▶ Safe use of headphones
 - ▶ Excessive volume when wearing headphones can cause damage to human hearing.



9. Safety

▶ Station Security

- ▶ An operable Amateur station must not be accessible to unauthorised persons





9. Safety

- ▶ Fuses are placed in circuits to protect against:
 - ▶ A). High currents
 - ▶ B). High voltage
 - ▶ C). High resistance
 - ▶ D). High frequency



9. Safety

- ▶ Batteries should be disposed of correctly because of the environmental issues the chemicals in them can cause. Batteries can also:
 - ▶ A). Produce electromagnetic radiation
 - ▶ B). Go flat very quickly if unused
 - ▶ C). Make loud noises
 - ▶ D). Explode or emit fumes if punctured



9. Safety

- ▶ Protective mains earths:
 - ▶ A). Should be removed during fault finding
 - ▶ B). Are not necessary in amateur radio stations
 - ▶ C). Can only be removed or replaced by qualified persons
 - ▶ D). Are always represented by a purple wire



9. Safety

- ▶ As well as EMR risk when working around functioning antennas another significant danger is:
 - ▶ A). A person falling while working at heights
 - ▶ B). Potential high voltages and currents
 - ▶ C). Sharp objects that can cause lacerations
 - ▶ D). Ice on antenna elements can make them fall



9. Safety

- ▶ High voltages and currents can be present around operating antennas. It is important that:
 - ▶ A). Earth mats are used at the antenna base
 - ▶ B). All wiring is insulated
 - ▶ C). People and animals are kept at a safe distance
 - ▶ D). Earth straps are used to conduct lightning away